

AMI240 AMI242

High-Performance Fanless System

User's Manual

Version 1.0
(April 2024)



Copyright

© 2024 IBASE Technology, Inc. All rights reserved.

No part of this publication may be reproduced, copied, stored in a retrieval system, translated into any language or transmitted in any form or by any means, electronic, mechanical, photocopying, or otherwise, without the prior written consent of IBASE Technology, Inc. (hereinafter referred to as “IBASE”).

Disclaimer

IBASE reserves the right to make changes and improvements to the products described in this document without prior notice. Every effort has been made to ensure the information in the document is correct; however, IBASE does not guarantee this document is error-free. IBASE assumes no liability for incidental or consequential damages arising from misapplication or inability to use the product or the information contained herein, nor for any infringements of rights of third parties, which may result from its use.

Trademarks

All the trademarks, registrations and brands mentioned herein are used for identification purposes only and may be trademarks and/or registered trademarks of their respective owners.

Compliance

CE

This product has passed CE tests for environmental specifications and limits. This product is in accordance with the directives of the Union European (EU). If users modify and/or install other devices in this equipment, the CE conformity declaration may no longer apply.

FCC

This product has been tested and found to comply with the limits for a Class B device, pursuant to Part 15 of the FCC Rules. These limits are designed to provide reasonable protection against harmful interference in a residential installation. This equipment generates, uses and can radiate radio frequency energy and, if not installed and used in accordance with manufacturer's instructions, may cause harmful interference to radio communications.

WEEE



This product must not be disposed of as normal household waste, in accordance with the EU directive of for waste electrical and electronic equipment (WEEE - 2012/19/EU). Instead, it should be disposed of by returning it to a municipal recycling collection point. Check local regulations for disposal of electronic products.

Green IBASE



This product is compliant with the current RoHS restrictions and prohibits use of the following substances in concentrations exceeding 0.1% by weight (1000 ppm) except for cadmium, limited to 0.01% by weight (100 ppm).

- Lead (Pb)
- Mercury (Hg)
- Cadmium (Cd)
- Hexavalent chromium (Cr6+)
- Polybrominated biphenyls (PBB)
- Polybrominated diphenyl ether (PBDE)

Important Safety Information

Carefully read the precautions before using the device.

Environmental conditions:

- Place the device horizontally on a stable and solid surface to prevent it from falling and causing serious damage.
- Make sure you leave plenty of space around the device for ventilation.
- Use this product in environments with ambient temperatures $-10^{\circ}\text{C} \sim 50^{\circ}\text{C}$.
- **DO NOT LEAVE THIS DEVICE IN AN ENVIRONMENT WHERE THE STORAGE TEMPERATURE MAY GO BELOW -20°C OR ABOVE 80°C .** This could damage the device. The device must be used in a controlled environment.

Care for your Industrial products:

- Before cleaning the device, turn it off and unplug all cables, including the power cable, to ensure no electrical current is flowing.
- Use neutral cleaning agents or diluted alcohol to clean the device chassis with a cloth. Then wipe the chassis with a dry cloth.
- Vacuum the dust with a computer vacuum cleaner to prevent the air vent or slots from being clogged.



WARNING

Attention during use:

- Do not use this product near water.
- Do not spill water or any other liquids on your device.
- Do not place heavy objects on the top of the device.
- Only operate this device with the type of power specified on the marking label. If you are not sure of the type of power available, consult your distributor or local power company.
- Avoid walking on the power cord or placing anything on it to prevent damage.
- If you use an extension cord, make sure that the total ampere rating of the product plugged into the extension cord does not exceed its limits.

Avoid Disassembly

Do not disassemble, repair, or modify the device in any way. Disassembly, modification, or any attempt at repair could generate hazards and cause damage to the device, even bodily injury or property damage, and will void any warranty.



CAUTION

For replacements, use only batteries of the same or equivalent type as recommended by the manufacturer. Dispose of used batteries following the manufacturer's instructions.

Warranty Policy

- **Industrial Standard Products:** Covered by a 24-month (2-year) warranty starting from the shipment date.
- **3rd-Party Parts:** Enjoy a 12-month (1-year) warranty from the delivery date for parts not manufactured by US.
- PRODUCTS FAILING DUE TO MISUSE, ACCIDENTS, IMPROPER INSTALLATION, OR UNAUTHORIZED REPAIRS WILL BE CONSIDERED OUT OF WARRANTY. CHARGES FOR REPAIR AND SHIPPING WILL APPLY.

Table of Contents

Chapter 1	General Information	1
1.1	Introduction	2
1.2	Features	2
1.3	Packing List	3
1.4	Optional Accessories	4
1.5	Specifications – AMI240 / AMI242	5
1.6	System View – AMI240	8
1.7	System View – AMI242	11
1.8	Dimensions – AMI240	15
1.9	Dimensions – AMI242	16
Chapter 2	Hardware Configuration	17
2.1	Essential Installations	18
2.1.1	Memory Installation	19
2.1.2	SSD Installation	20
2.1.3	SIM Cards Installation	21
2.1.4	WiFi / 3G / 4G Antenna Installation	22
2.1.5	Wall Mount Installation	23
2.1.6	M.2 Thermal Kit Installation	24
2.1.7	AMI242 Series Disassembly / Installations	25
2.2	Setting the Jumpers	28
2.3	Jumper & Connector Locations on Motherboard	29
2.4	Jumpers Quick Reference	30
2.4.1	JP3: Sierra EM9191 5G Card USB/PCIe Select	30
2.4.2	JP4: Clear ME Contents	31
2.4.3	JP5: Clear CMOS Data	31
2.4.4	JP6: Flash Descriptor Security Override	32
2.4.5	JP7: PCIe (x16) Bifurcation Select	32
2.4.6	JP8, JP9, JP11: Factory use only	33
2.4.7	JP16, JP15, JP14, JP13: COM1/COM2/COM3/COM4 RS232 RI/+5V/+12V Power Setting	33
2.4.8	JP12: ATX/AT Select	33

2.5	Connectors Quick Reference	34
2.5.1	J1: Reset Button Connector (Techbest 01017021001-L)	35
2.5.2	J3: M.2 B-Key 3052 Slot	35
2.5.3	J5: Audio Connector	36
2.5.4	J6: SPI Flash Connector	36
2.5.5	J7: M.2 M-Key M2280 Slot.....	37
2.5.6	J8: Factory use only.....	37
2.5.7	J9: M.2 E-Key E2230 Slot.....	38
2.5.8	J11, J12: SATA Power Connector	38
2.5.9	J4, J17: DDR5 Memory Sockets.....	39
2.5.10	J13: 80 Port Debug (Factory use only)	39
2.5.11	J14: Digital I/O Connector.....	40
2.5.12	J15: DC-in Connector	40
2.5.13	J16: DC-in Connector (Dinkle 5EHDRM-05P).....	41
2.5.14	LED1 : HDD LED.....	41
2.5.15	LED3: CN13 PoE LED.....	42
2.5.16	LED4: CN12 PoE LED.....	42
2.5.18	CN1, CN14 : Nano SIM card 2, Nano SIM card 1 Slot	43
2.5.19	CN2: 2.5 Gigabit LAN (Intel I226-V) + USB 3.2.....	43
2.5.20	CN3: 2.5 Gigabit LAN (Intel I226-LM) + USB 3.2	43
2.5.21	CN4: USB 3.2 Connector.....	44
2.5.22	CN5: HDMI Port x2	44
2.5.23	CN6: Power Button Connector (Dinkle ECH350RM-02P)	45
2.5.24	CN8, CN7: SATA III Connectors.....	45
2.5.25	CN9: COM3 & COM4 RS-232 Ports	46
2.5.26	CN10: COM1 & COM2 RS-232/422/485 Ports.....	47
2.5.27	CN11: DisplayPort x2	48
2.5.28	CN12: Gigabit LAN (Intel I210IT) + PoE+	48
2.5.29	CN13: Gigabit LAN (Intel I210IT) + PoE+	48
2.5.30	PCIE1: For PCI-E x1, USB 2.0 Sys_Fan, SATA, COM TX/RX Signal	49
2.5.31	PCIE2: PCIE-E x16 Connector	49
Chapter 3	Driver Installation	50
3.1	Introduction	51
3.2	Intel® Chipset Software Installation Utility.....	51
3.3	Graphics Driver Installation	53
3.4	HD Audio Driver Installation	55
3.5	LAN Drivers Installation.....	56
3.6	Intel® Management Engine Driver Installation	58
3.7	Intel® Serial IO Drivers Installation.....	59

Chapter 4	BIOS Setup	60
4.1	Introduction	61
4.2	BIOS Setup	61
4.3	Main Settings	62
4.4	Advanced Settings	63
4.5	Chipset Settings	74
4.6	Security Settings	77
4.7	Boot Settings	79
4.8	Save & Exit Settings	80
4.9	MEBx	81
Appendix		82
A.	I/O Port Address Map	83
B.	Interrupt Request Lines (IRQ)	85
C.	Watchdog Timer Configuration	86

Chapter 1

General Information

The information provided in this chapter includes:

- Features
- Packing List
- Optional Accessories
- Specifications
- Product View
- Dimensions

1.1 Introduction

The AMI240 system offers a fanless design for powerful performance and robust connectivity, integrating the MBE240 board with support for 14th/13th Gen Intel® Core™ i9/i7/i5/i3 Desktop Processors for seamless multitasking in demanding applications. It features dual SIM slots for WWAN redundancy across 5G/4G/LTE, four Ethernet ports including two 2.5GbE and two PoE+ for high-speed data transfer, and three M.2 slots (B-Key/E-Key/M-Key), enhanced with iAMT (16.1) and TPM (2.0) for security and management. Designed for reliability in industrial and commercial use, the AMI240 includes comprehensive voltage protections.



AMI240

1.2 Features

- Fanless system with MBE240 customized board
- 14th/13th Gen Intel® Core™ i9/i7/i5/i3 Desktop Processors
- Dual SIM slots support WWAN redundancy (5G/4G/LTE)
- 4x RJ45 Ethernet ports (2x 2.5GbE ports + 2x PoE+ ports support 802.3at)
- 3x M.2 (B-Key/E-Key/M-Key), iAMT (16.1), TPM (2.0)
- Single 24V DC input, supports Over/Under/Reverse voltage protection

1.3 Packing List

Your product package should include the items listed below. If any of the items below is missing, contact the distributor or the dealer from whom you purchased the product.

AMI240 Series

- AMI240 x 1
- Terminal Block for DC-In Power Adaptor (5 pins) x 1
- Terminal Block for Remote Power Button (2 pins) x 1
- Wall Mount Kit x 1
- Flat Head Screw (for Wall Mount Kit) x 6



AMI242 Series

- AMI242 x 1
- Terminal Block for DC-In Power Adaptor (5 pins) x 1
- Terminal Block for Remote Power Button (2 pins) x 1
- Wall Mount Kit x 1
- Flat Head Screw (for Wall Mount Kit) x 6



- Flat Head Screw for 2nd SSD (if not pre-installed) x 4



1.4 Optional Accessories

AMI240

- 270W (24V@11.25A) DC-In Power Adaptor kit
- WiFi or 4G/LTE Antenna Kit
- M.2 Thermal Kit (Storage for M.2) (PN: SC2AMI240--0A1100R)
- 4G Module (PN: A024MDWIFI0040700P);
M.2 LTE/GPS (Global) [Sierra EM7565]
- Wireless, M.2-2230 A E Key B2 (PN: A008WIRELESS02200P);
802.11A/B/G/N/AC+BT [AW-CB260NF] RoHS2
- Power cord

AMI242

- 330W (24V@13.75A) DC-In Power Adaptor kit
- WiFi or 4G/LTE Antenna Kit
- M.2 Thermal Kit (Storage for M.2) (PN: SC2AMI240--0A1100R)
- Expansion Kit (with 2 cables for COM5 & COM6 ports): IP211, IP212
- 4G Module (PN: A024MDWIFI0040700P);
M.2 LTE/GPS (Global) [Sierra EM7565]
- Wireless; M.2-2230 A E Key B2 (PN: A008WIRELESS02200P);
802.11A/B/G/N/AC+BT [AW-CB260NF] RoHS2
- Sierra EM9191 5G module [A024MD5GEM9191010P]
- IP218 riser card for 1-slot PCIe(16x) @ G5
- Power cord
- Riser card kits:
 - IP211 Riser Card Kit with 2x COM cables
 - IP212 Riser Card Kit with 2x COM cables
 - IP213 Riser Card Kit w/o COM cable
 - IP218 Riser Card Kit supporting PCI-E Gen. 5

1.5 Specifications – AMI240 / AMI242

Product Name	AMI240 series Fanless Box System supporting Intel Core i9/i7/i5/i3 desktop CPU (35W), with 2x DDR5 SO-DIMM (Max. 64GB), 1x SATA 2.5" storage device, w/o power adaptor
	AMI242 series Fanless Box System supporting Intel Core i9/i7/i5/i3 desktop CPU (35W), with 2x DDR5 SO-DIMM (Max. 64GB), 1x SATA 2.5" storage device, w/o power adaptor; plus 2x RS232 for COM#5/#6, 2x USB 2.0, 1x PCIe(x16), 1x PCIe(x4)
System	
Motherboard	MBE240AF
Operating System	<ul style="list-style-type: none"> • Windows 10 (64-bit) • Linux Ubuntu / Fedora 24
CPU	14th/13th Gen Intel® Core™ i9/i7/i5/i3 Desktop Processors
Chipset	<ul style="list-style-type: none"> • Intel® Q670E (AMI240AF / AMI242AF) • Intel® R680E (AMI240AF-R / AMI242AF-R)
Memory	2x DDR5-4800/5600 SO-DIMM, Max. 64GB <i>Note1: ECC for AMI242AF-R only.</i> <i>Note2: DDR5-5600 for Core i9/i7 processors</i>
Super I/O	Fintek F81966-I
Audio Codec	Realtek ALC888S-VD2-GR
Network	<ul style="list-style-type: none"> • Intel® I226LM 2.5GbE, Intel® I226V 2.5GbE • Intel® I210IT GbE, Intel® I210IT GbE
SATA	<ul style="list-style-type: none"> • 2x SATA III port for 2.5" SATA HDD or SSD
M.2	<ul style="list-style-type: none"> • M.2(E-Key @2230), for CNVi, w/ 1x PCIe(1x)+USB2.0 • M.2(M-Key @2280), for NVMe, w/ 1x PCIe(4x)(G4)+SATA • M.2(B-Key @3052), for 5G/4G/LTE, w/ 1x PCIe(1x)+USB 3.2
Front Panel I/O	<ul style="list-style-type: none"> • 2x HDMI (2.0b) • 1x Audio jack for MIC / Line-out • 4x USB 3.2 ports • 2x Antenna holes • 2x RJ45 2.5GbE ports + Dual USB 3.2 stack ports • 1x Red LED for 2.5" storage device status • 1x Power button with Green LED indicator • 1x 2-pin terminal block for external power button • 1x SIM card cover for 2x SIM slots
Rear Panel I/O	<ul style="list-style-type: none"> • 2x RS232/422/485 ports for COM#1~COM#2 • 2x RS232 ports for COM#3~COM#4 • 2x RS232 ports for COM#5/#6 [Reserved for AMI242] • 2x USB 2.0 Type A connectors [Reserved for AMI242] • 2x DisplayPort (1.2) (supports DP++) • 2x RJ45 Gigabit Ethernet ports (supports 802.3at,PoE+) • 1x 5-pin DC-in terminal block for 24V DC input • 2x Antenna holes

Expansion Slots	<ul style="list-style-type: none"> • 1x PCI-E (x16) expansion slot [Reserved for AMI242] • 1 x PCI-E (x4) expansion slot [Reserved for AMI242]
Storage	<ul style="list-style-type: none"> • 1x 2.5 HDD/SSD • 1x M.2 (M-Key) • *Supports NVMe SSD

Mechanical and Environmental	
Dimensions	210mm(W) x 285mm(D) x 77mm(H)
Construction	Aluminum & steel
Chassis color	Silver + Gray (Aluminum)
Mounting type	Desktop & Wall mount
Operating Temperature	-20°C to 70°C (-4°F~158°F) (for 35W CPU)
Storage Temperature	-20°C~80°C (-4°F~176°F)
Humidity	5%~90% @ 45°C (non-condensing)
Vibration	Operating: 3Grms / 5~500Hz
Shock	Operating: 20G / 11ms Non-operating: 40G / 11ms
Certification	CE *follow EN55032* FCC Class-A / LVD

All specifications are subject to change without prior notice.

Mechanical and Environmental	
Dimensions	210mm(W) x 285mm(D) x 129mm(H)
Construction	Aluminum
Chassis color	Silver + Gray
Mounting type	Desktop & Wall mount
Operating Temperature	-20°C to 70°C (-4°F~158°F) (for 35W CPU)
Storage Temperature	-20°C~80°C (-4°F~176°F)
Humidity	5%~90% @ 45°C (non-condensing)
Vibration	Operating: 3Grms / 5~500Hz
Shock	Operating: 20G / 11ms Non-operating: 40G / 11ms
Certification	CE FCC Class A / LVD IP40

Compatible Expansion Cards for AMI242 series:

Name	Features
IP211	1x PCIe (x1), 1x PCIe (x8), 2x COM (COM5 & COM6), 1x SATA II, 2x USB 2.0
IP212	1x PCIe (x16), 2x COM (COM5 & COM6), 1x SATA II, 2x USB 2.0
IP213	1x PCI, 1 x PCIe (x16), 1x SATA III, 2x USB 2.0
IP214	1x PCIe (x16), 2x COM (COM5 & COM6), 2x USB 2.0
IP215	1x PCI, 2x COM (COM5 & COM6), 2x USB 2.0

All specifications are subject to change without prior notice.

1.6 System View – AMI240

Front View

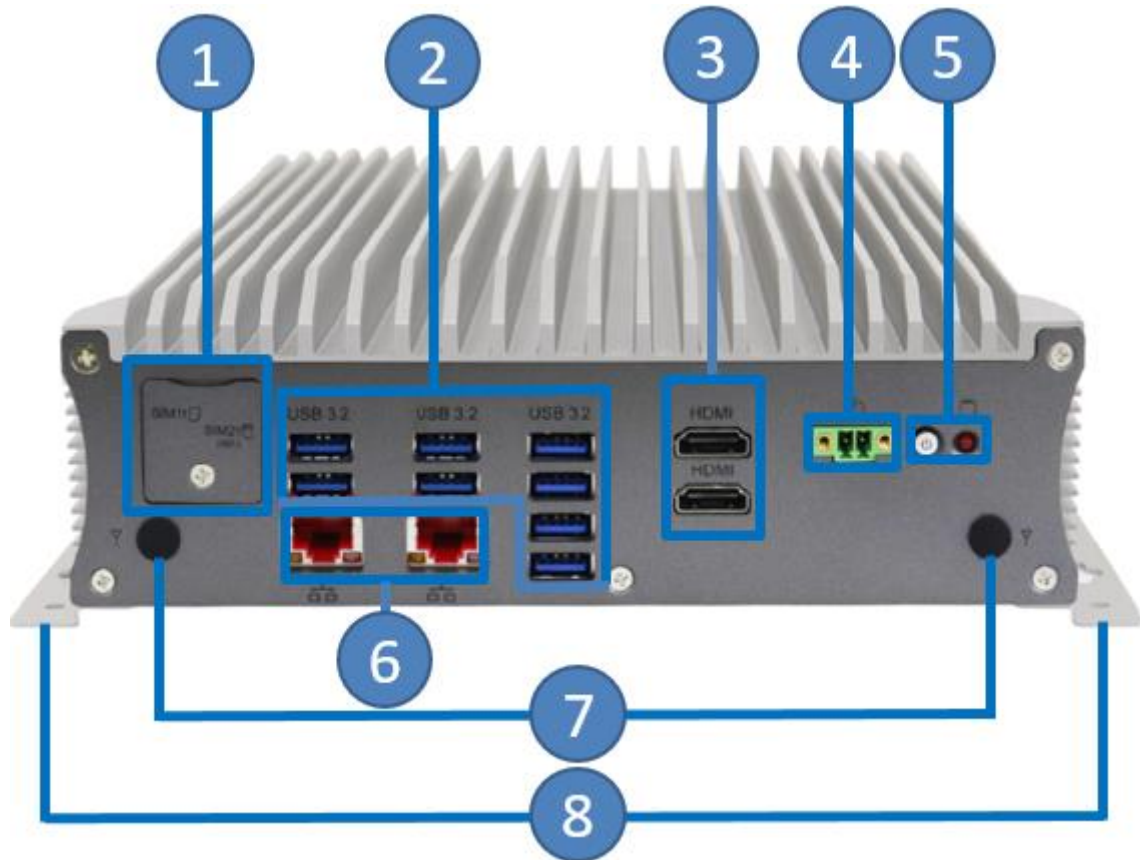

No.	Name	No.	Name
1	SIM Card Slots	5	Power Button and LED Indicator for HDD
2	USB Ports	6	RJ45
3	HDMI	7	Antenna holes
4	Terminal Block for external Power Button	8	Mounting Brackets

Rear View

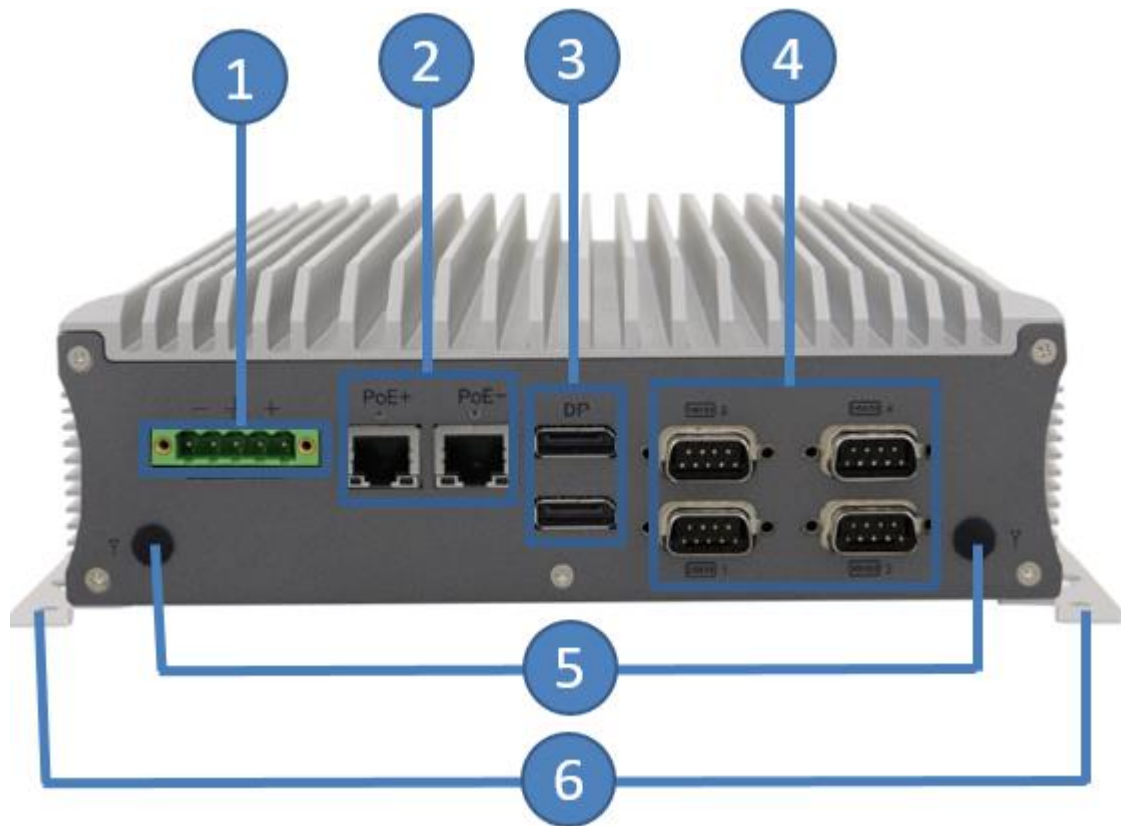

No.	Name	No.	Name
1	DC-In Power Connector for 24V input	4	4x COM Ports
2	2x RJ45 port (supports 802.3at, PoE+)	5	Antenna hole for WiFi/BT and 4G/LTE module
3	DisplayPort	6	Mounting Brackets

AMI240 Pictures



1.7 System View – AMI242

Front View

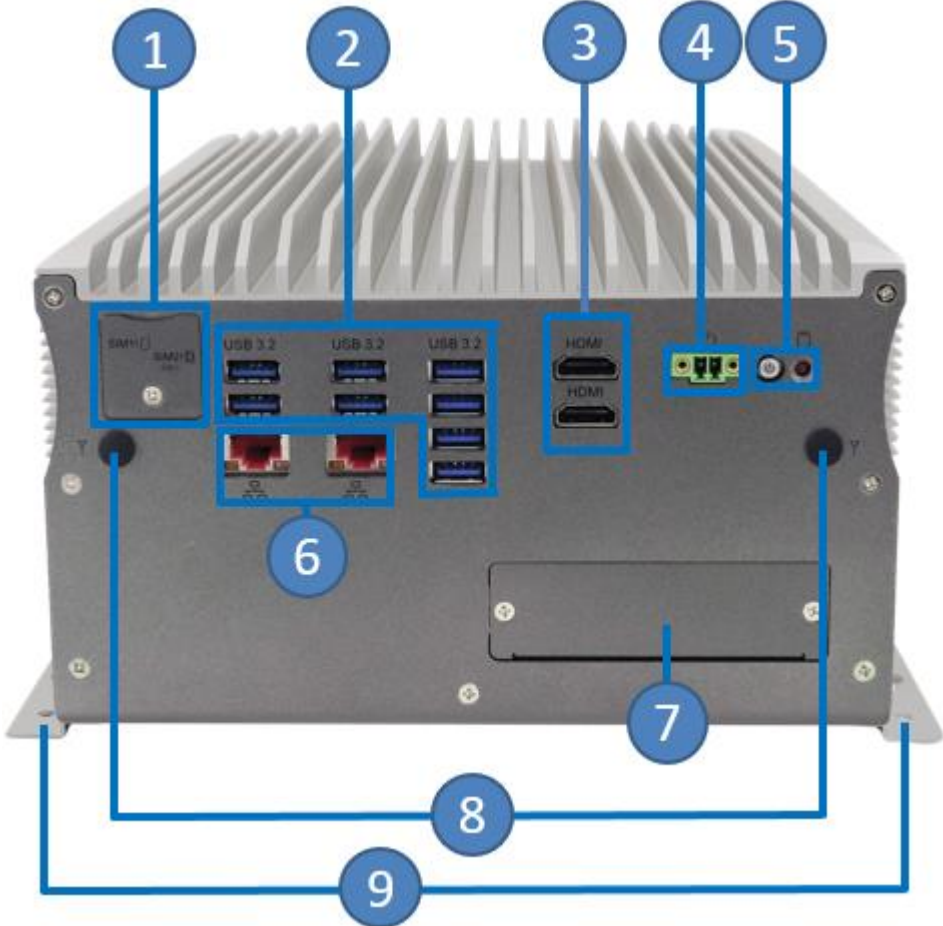

No.	Name	No.	Name
1	SIM Card Slots	6	RJ45
2	USB Ports	7	Reserved
3	HDMI	8	Antenna holes
4	Terminal Block for external Power Button	9	Mounting Brackets
5	Power Button & LED Indicator for HDD		

Rear View

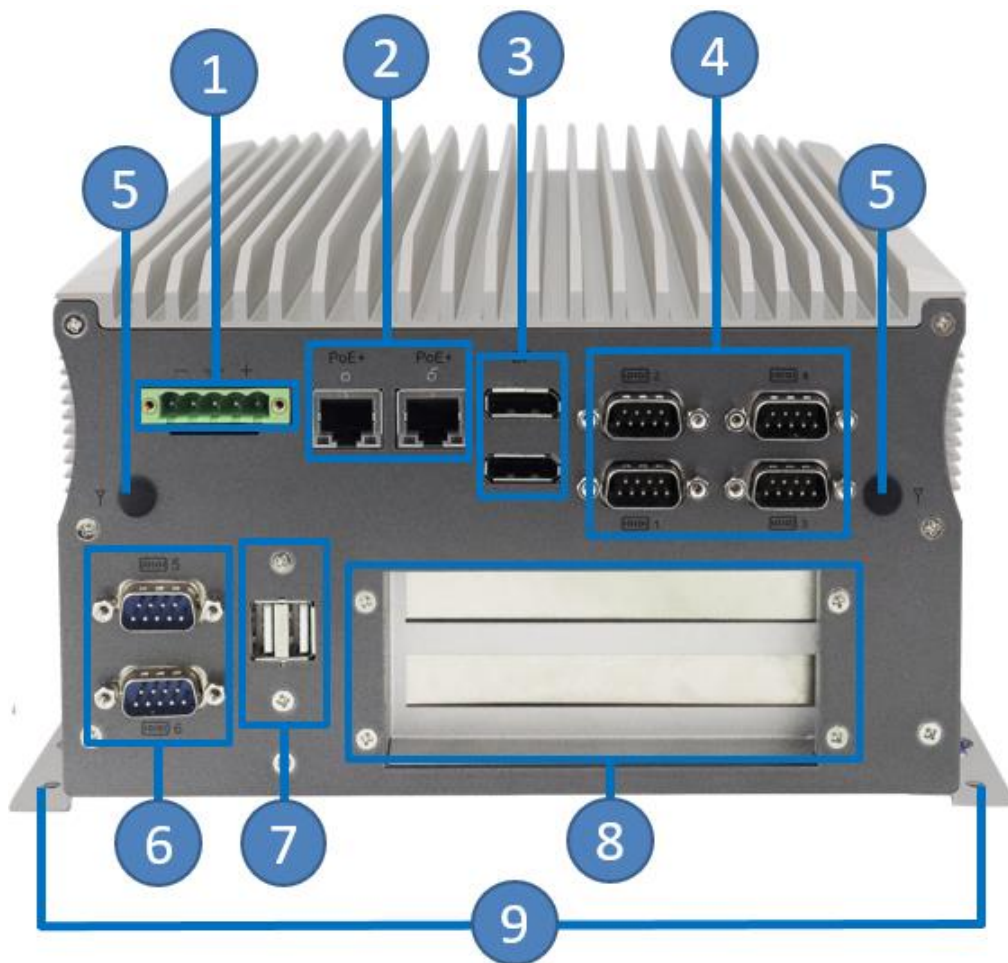

No.	Name	No.	Name
1	DC-In Power Connector for 24V input	6	COM5/COM6 (reserved)
2	2x RJ45 port (supports 802.3at, PoE+)	7	USB ports (reserved)
3	DisplayPort	8	Expansion Slots (reserved)
4	4x COM Ports	9	Mounting Brackets
5	Antenna hole for WiFi/BT and 4G/LTE module		

AMI242 Pictures



1.8 Dimensions – AMI240

Unit: mm

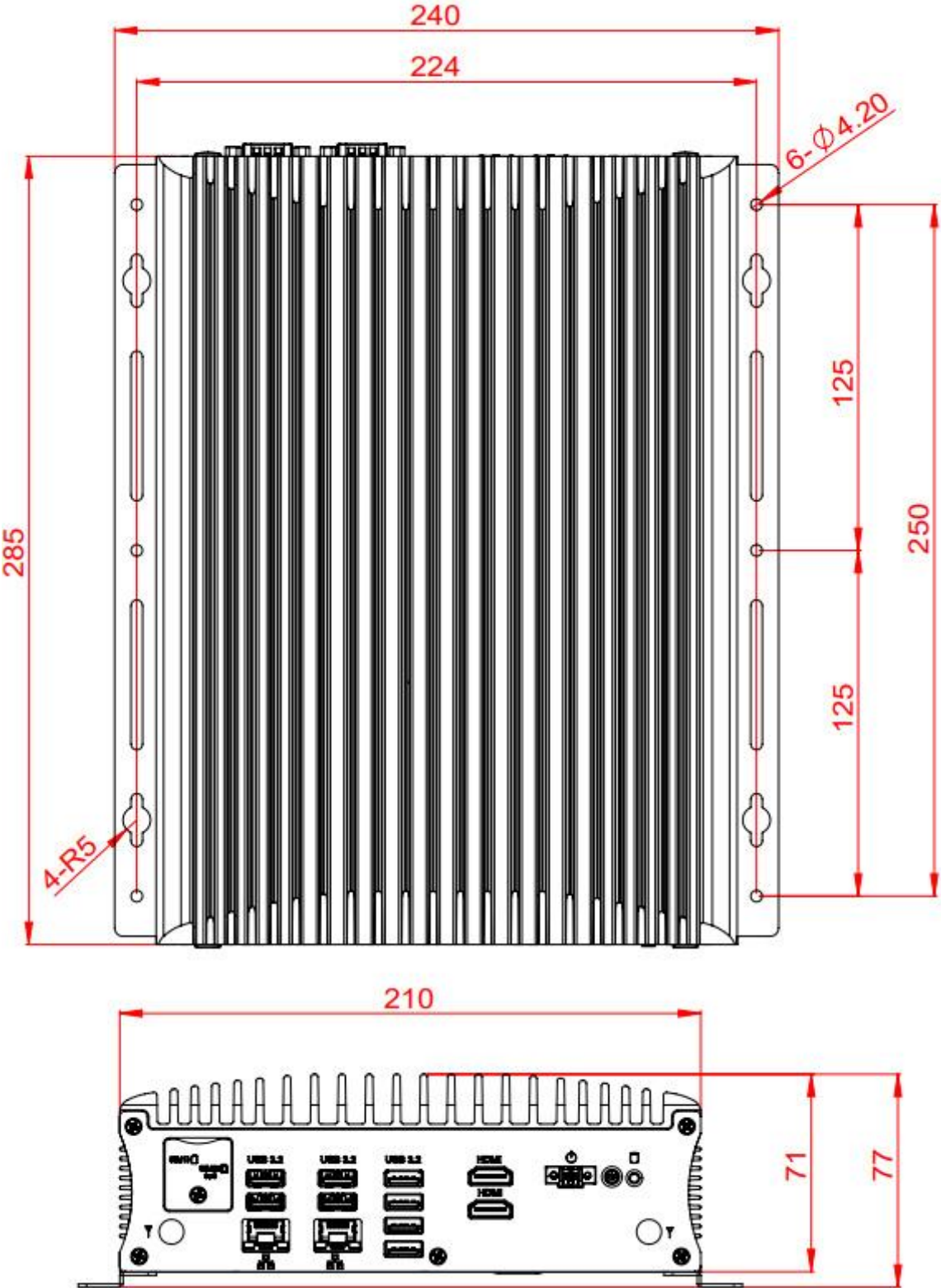

1.9 Dimensions – AMI242

Unit: mm

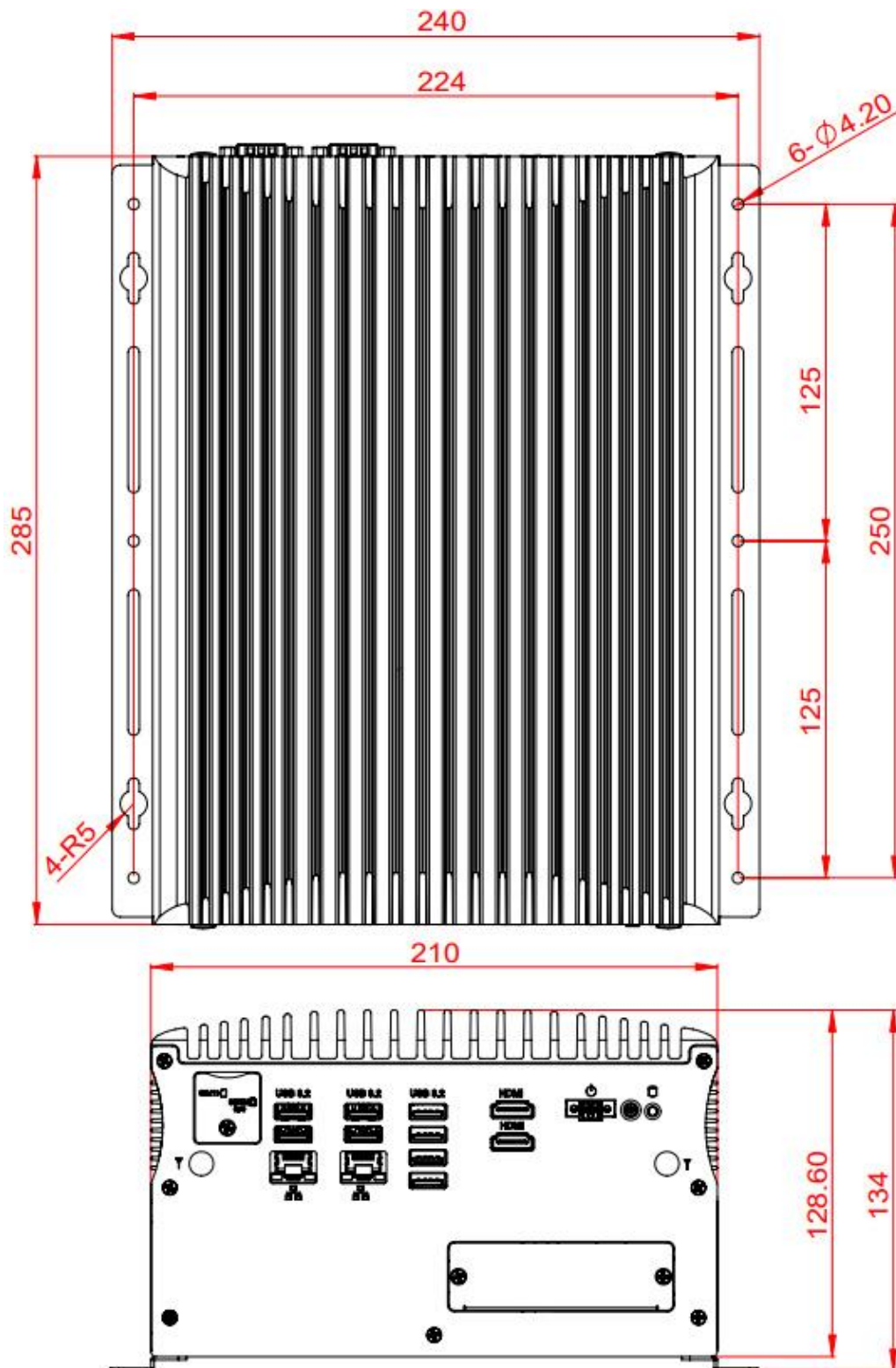

Chapter 2

Hardware Configuration

The information provided in this chapter includes:

- Essential installations
- Information and locations of connectors

2.1 Essential Installations

Remove the system bottom cover for all installations except the one for SIM cards and externally accessed SSD. Secure the cover after every installation.

Release the 10 screws to remove the device bottom cover.

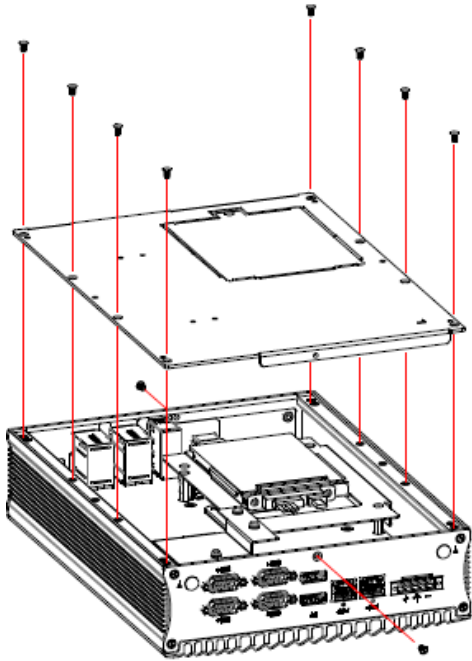

This illustration below shows how to remove/install the M.2 module. Three (3) screws have to be unscrewed to remove the plate securing the M.2 module.

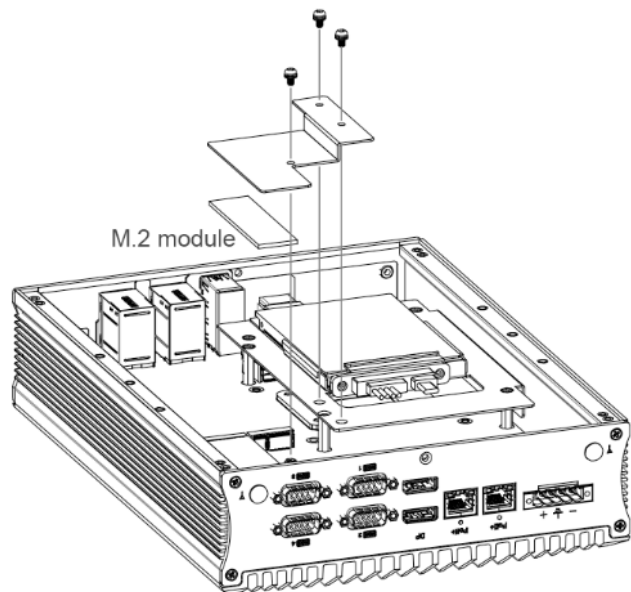

2.1.1 Memory Installation

Perform the following steps to replace or install the memory modules.

The memory slots on the motherboard are situated right beside the processor. To access the slot, release the screws (4) on the standoffs that are holding the storage device kit. To install a memory module, align the key of the memory module with that on the memory slot.

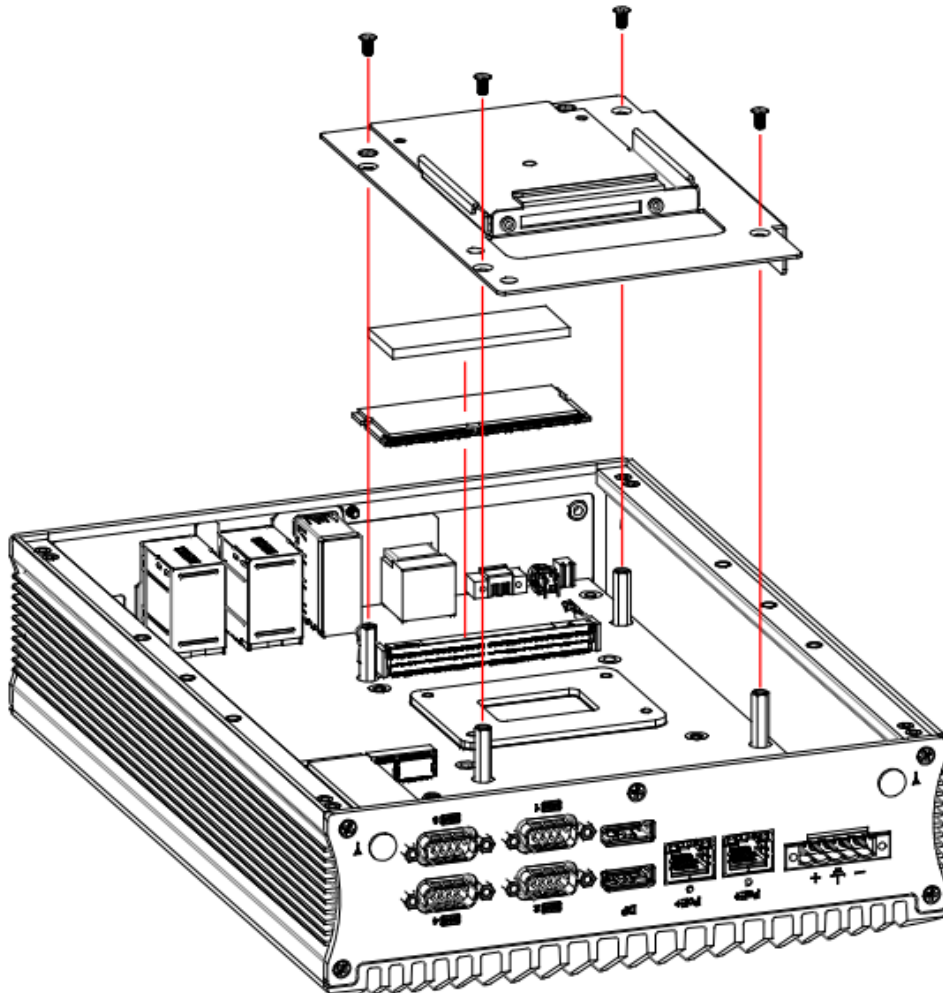

Insert the module slantwise and gently push the module straight down until it touches the bottom of the slot, at which point the slot's clips should snap closed, securing the module in place. To remove the module, press the clips outwards with both hands.

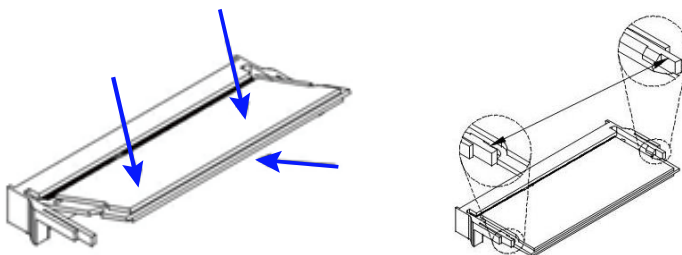

2.1.2 SSD Installation

Perform the following steps to replace or install the SSD located on the same side of the mounting brackets.

AMI240

1. Ensure the system is powered off and unplugged. With the system upside down, loosen the SSD compartment screw.
2. Pull the cover away to remove or install the SSD onto the bay. Unlike accessing the memory slot, there is no need to remove any storage kit for this process.
3. After the SSD removal/installation, securely tighten the compartment cover screw without over-tightening.

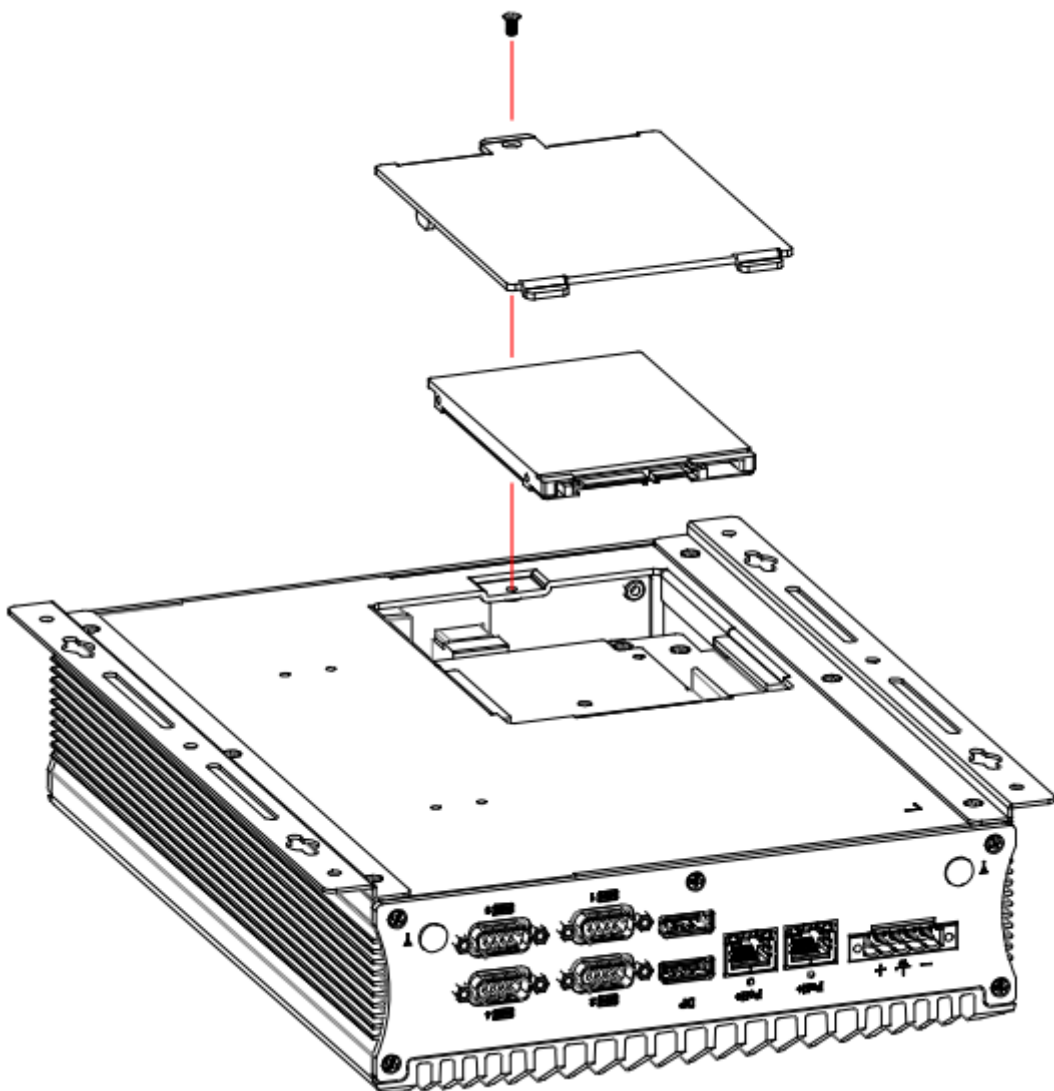

2.1.3 SIM Cards Installation

Release the single screw to open the SIM card slot door. Insert the SIM into one of the slots and push the card again if you want to remove it. Replace the screw to return the SIM card slot door in place

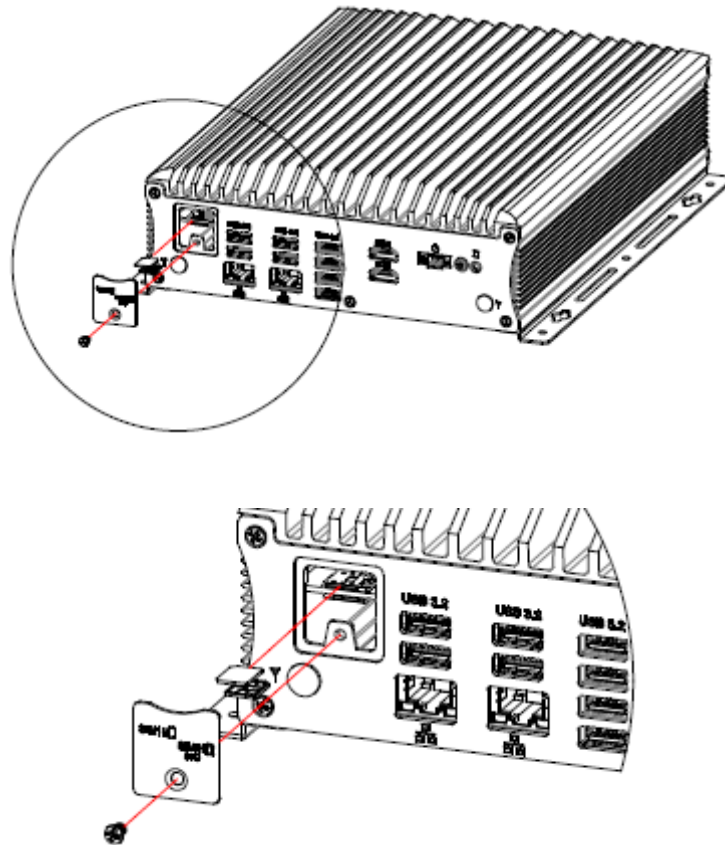

2.1.4 WiFi / 3G / 4G Antenna Installation

Carefully thread the WiFi / 3G / 4G antenna extension cable through one of the antenna holesc. Next, apply adhesive to the edge of the hex nut behind the front I/O cover to prevent the extension cable from falling if it becomes loose.

1. Thread and fasten the hex nut and the washer. Then install the antenna.

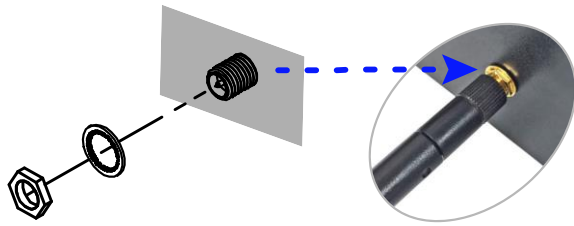

2. Apply adhesive around here.

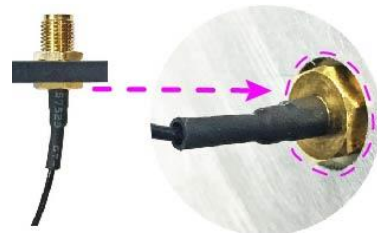

Info: The diameter of the nut is around 6.35 mm (0.25"-36UNC).

2.1.5 Wall Mount Installation

Prior to wall mounting the system, verify there's adequate space for routing both power and signal cables. Equally important, confirm the mounted area provides sufficient ventilation to prevent overheating. Select a mounting method that can safely support not only the system's weight but also the additional weight of all connected cables. Ensure the mounting hardware and wall structure are adequate for the total load.

Wall mount installation instructions:

This is illustrated below using AMI240.

1. Attach the mounting brackets to the system and secure them with the supplied 6 screws.

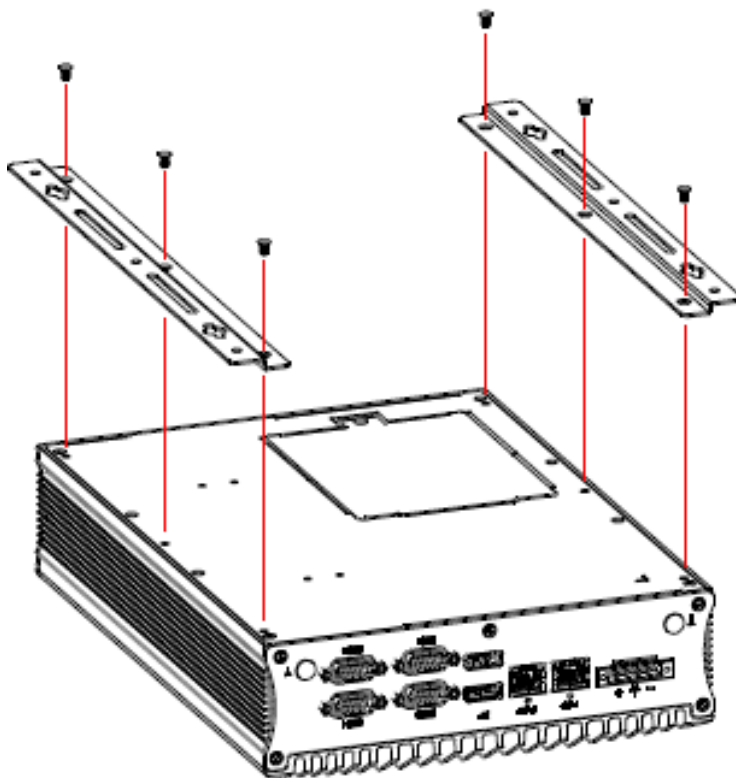

2. Prepare at least 4 screws (M3) to mount the system to the desired wall or location.

2.1.6 M.2 Thermal Kit Installation

The M.2 SSD Cooling Kit is designed to efficiently cool down M.2 2280 SSDs and prevent thermal throttling. It helps improve performance, increase durability, and enhance the data integrity of solid-state drives. The kit includes an ultra-slim aluminum bracket and specially crafted thermal pads to provide optimal heat transfer, maintaining significantly lower operating temperatures for memory ICs and other electronic components of the M.2 SSD. (M.2 Thermal Kit, PN: SC2AMI240--0A1100R)

To install the M.2 SSD Cooling Kit, locate the three screws included with the kit. These will be used to secure the bracket over the M.2 SSD, ensuring the thermal pads are properly positioned between the SSD and the bracket for optimal heat transfer, as shown in the picture below.

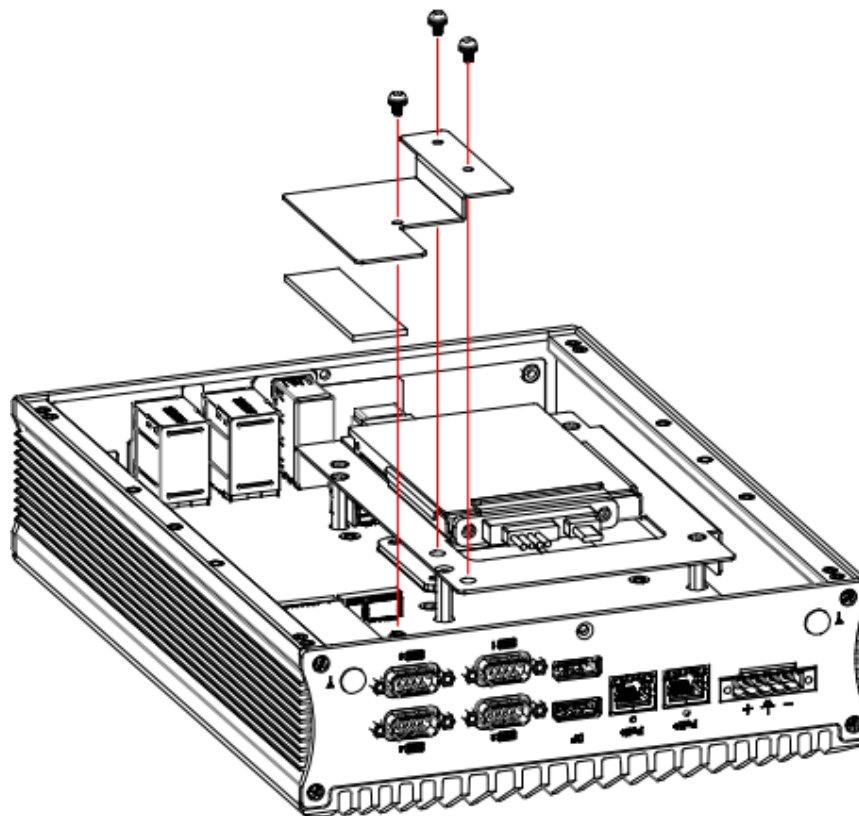

2.1.7 AMI242 Series Disassembly / Installations

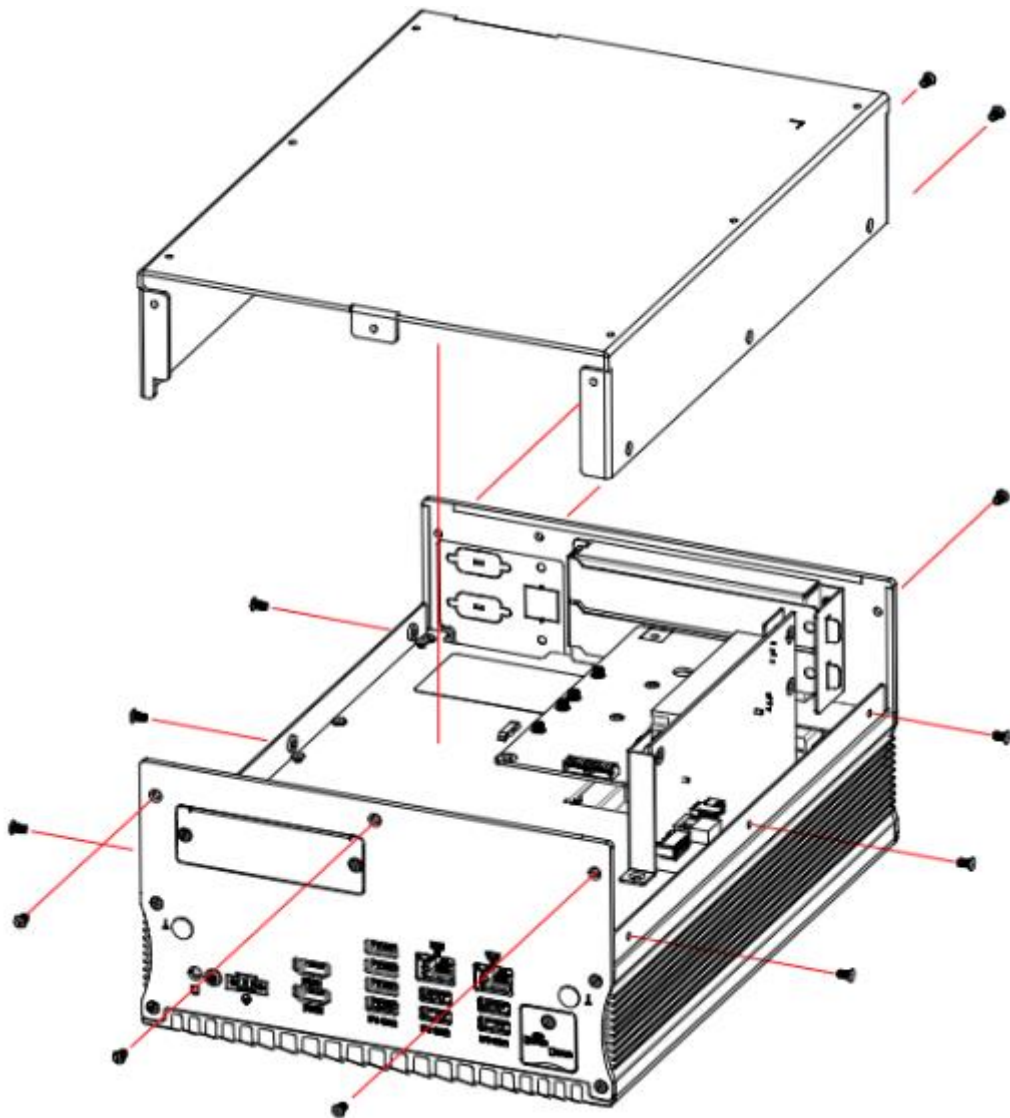

The above illustration shows all the screws that need to be unscrewed in order to remove the cover.

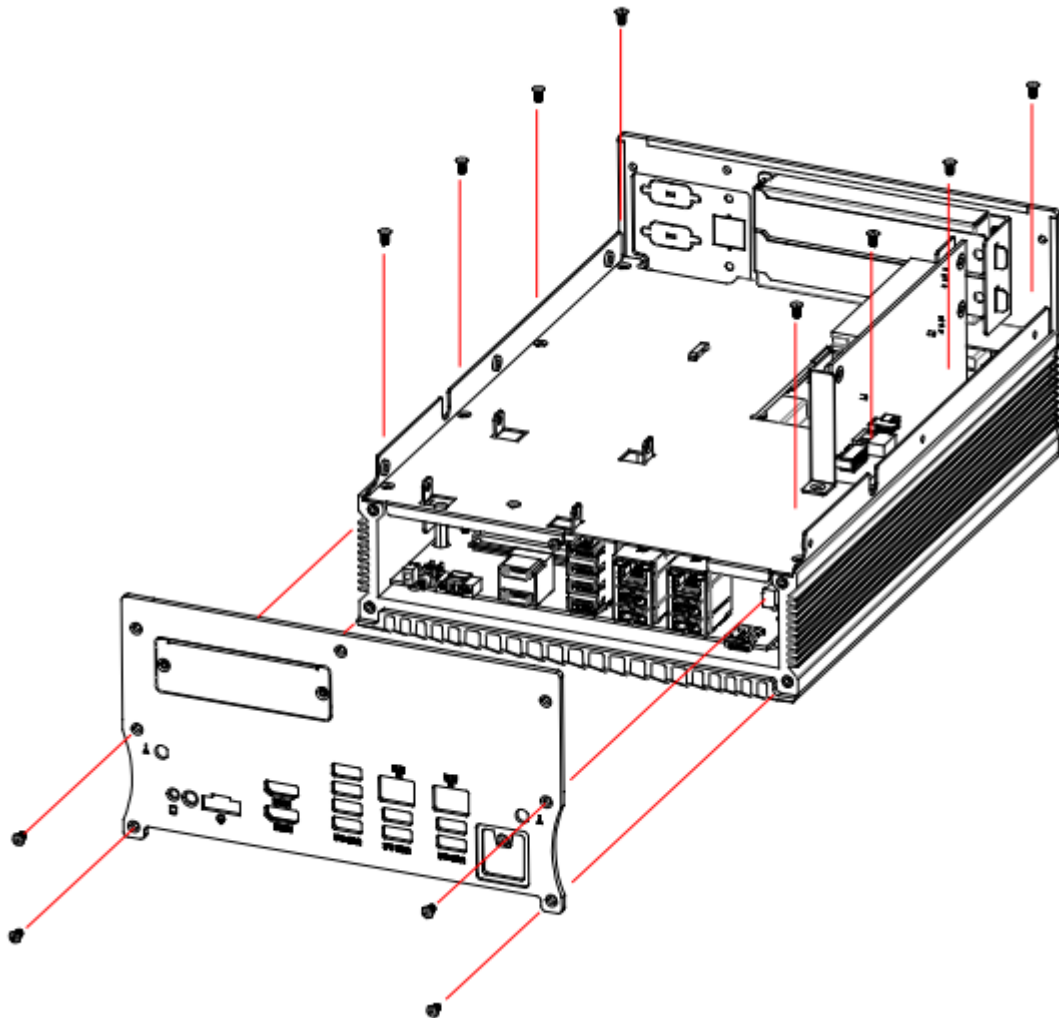

The above illustration shows all the screws that need to be unscrewed in order to expose the parts of the lower compartment.

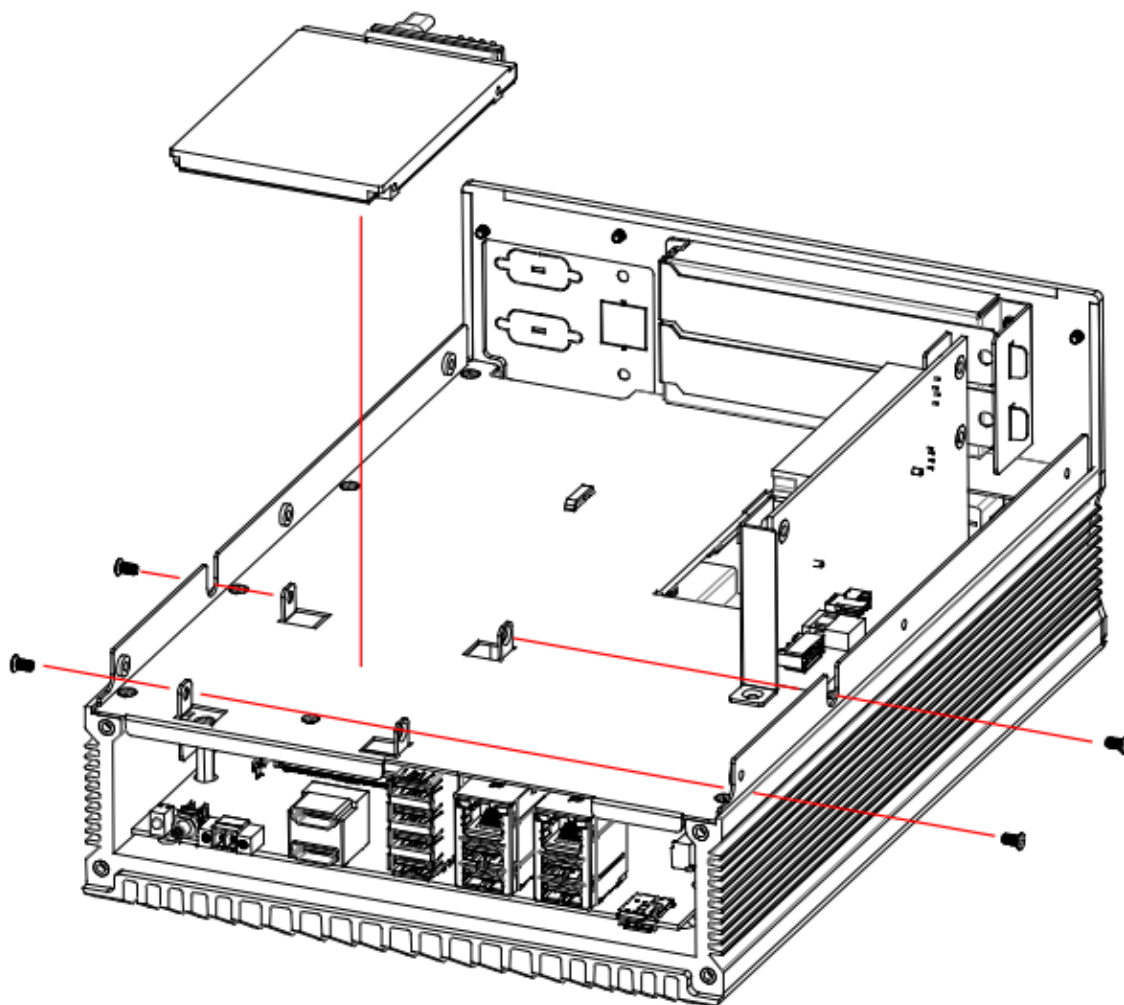

The above illustration shows all the screws that need to be unscrewed in order to remove the SSD storage device.

2.2 Setting the Jumpers

Whether you need to adjust jumper settings depends on if the default setup fits your needs, specific functionalities you require, upgrades, or troubleshooting hardware issues. If you have any doubts about the best configuration for your use, please contact your supplier.

2.2.1 How to Set Jumpers

Jumpers are short-length conductors consisting of several metal pins mounted on a non-conductive base on the circuit board. Jumper caps are used to enable or disable functions and features. If a jumper has 3 pins, you can short either PIN1 to PIN2 or PIN2 to PIN3 to make the desired connection.

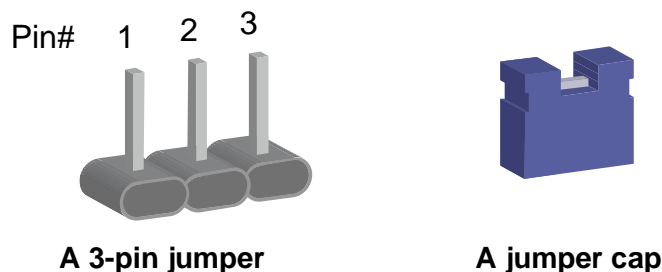

Pin closed	Oblique view	Illustration
Open		
1-2		
2-3		

When two pins of a jumper are encased in a jumper cap, this jumper is **closed**, i.e. turned **On**.

When a jumper cap is removed from two jumper pins, this jumper is **open**, i.e. turned **Off**.

2.3 Jumper & Connector Locations on Motherboard

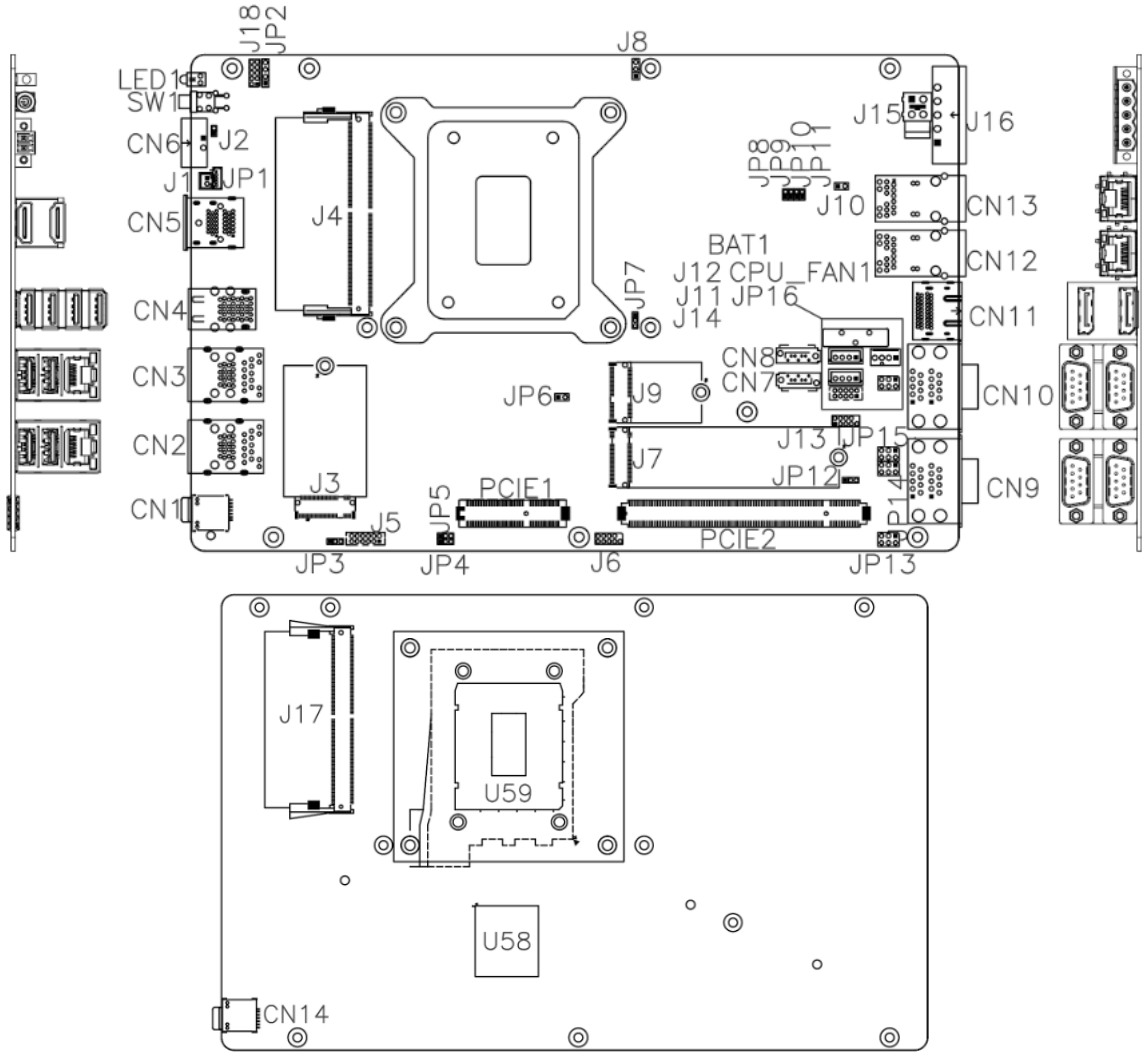

MBE240 Motherboard

2.4 Jumpers Quick Reference

Function	Jumper	Page
Sierra EM9191 5G Card USB/PCIe Select	JP3	30
Clear ME Contents	JP4	31
Clear CMOS Data	JP5	31
Flash Descriptor Security Override	JP6	32
PCIe (x16) Bifurcation Select	JP7	32
Factory use only	JP8, JP9, JP10, JP11	33
COM1/COM2/COM3/COM4 RS232 RI/+5V/+12V Power Setting	JP16, JP15, JP14, JP13	33
ATX/AT Select	JP12	33

2.4.1 JP3: Sierra EM9191 5G Card USB/PCIe Select

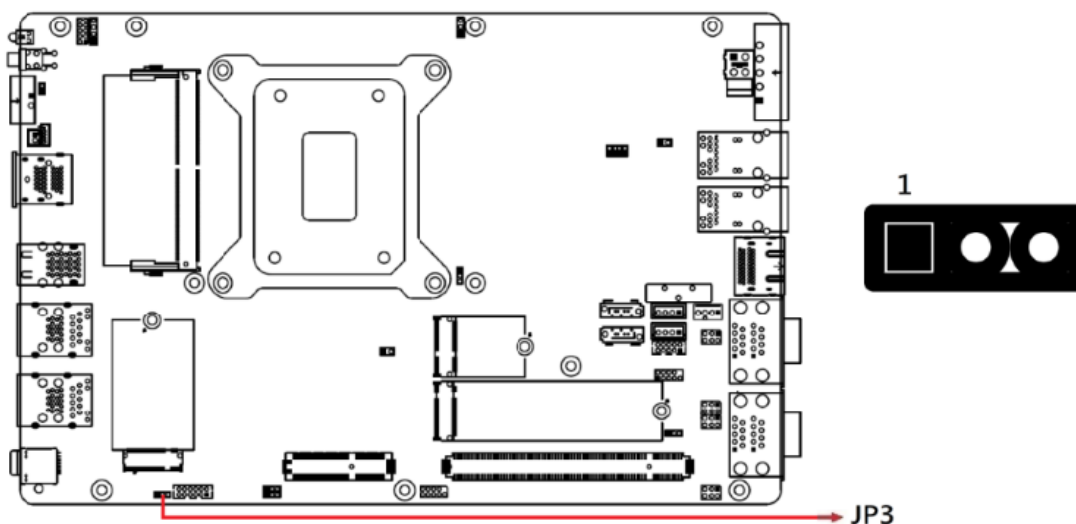

Function	Pin closed	Illustration
USB	1-2	1
PCIe (default)	2-3	1

2.4.2 JP4: Clear ME Contents

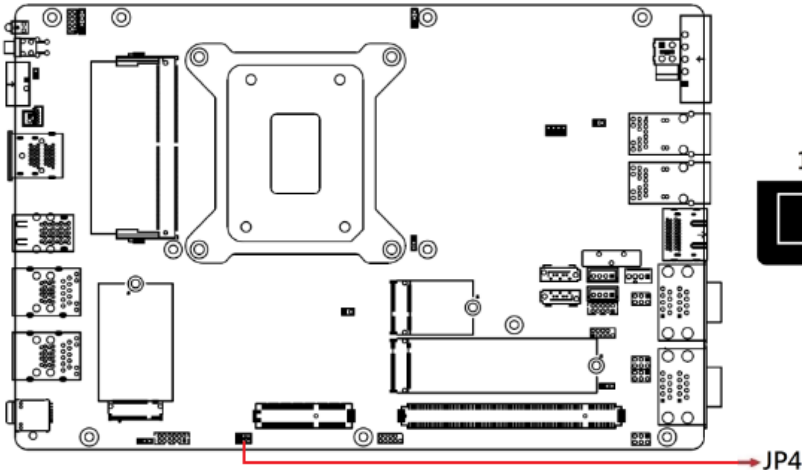

Function	Pin closed	Illustration
Normal	1-2	1
Clear ME	2-3	1

2.4.3 JP5: Clear CMOS Data

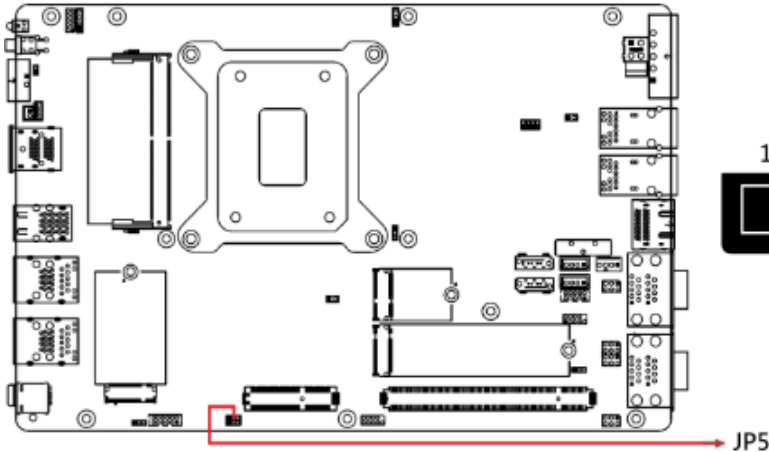

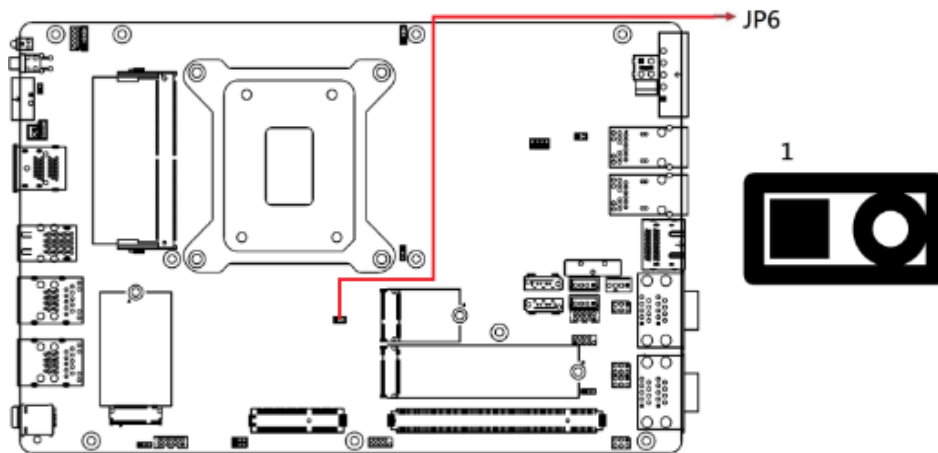

Function	Pin closed	Illustration
Normal (default)	1-2	1
Clear CMOS	2-3	1

2.4.4 JP6: Flash Descriptor Security Override



Note: JP6 is for factory use only.

Flash Descriptor Security Override	Pin	Illustration
Disabled (default)	Open	 1
Enabled	Close	 1

2.4.5 JP7: PCIe (x16) Bifurcation Select

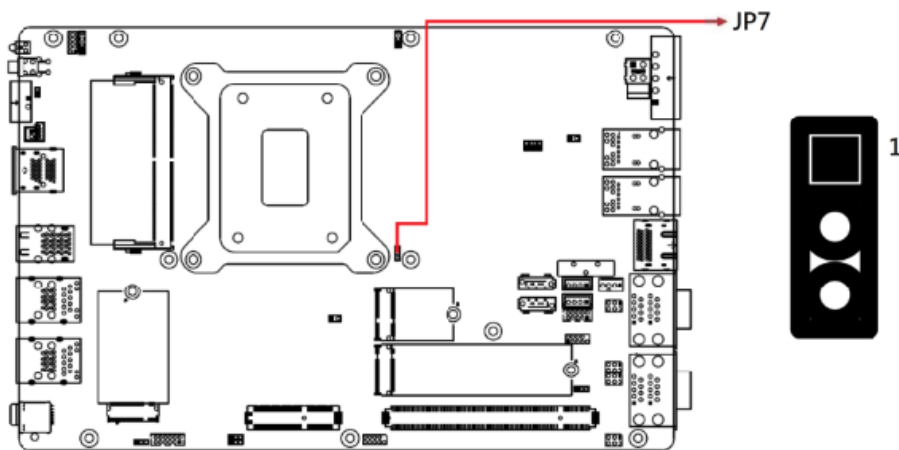

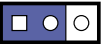
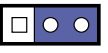
Function	Pin closed	Illustration
1 x PCIe (x16) (default)	1-2	1 
2 x PCIe (x8)	2-3	1 

2.4.6 JP8, JP9, JP11: Factory use only

2.4.7 JP16, JP15, JP14, JP13: COM1/COM2/COM3/COM4 RS232 RI/+5V/+12V Power Setting

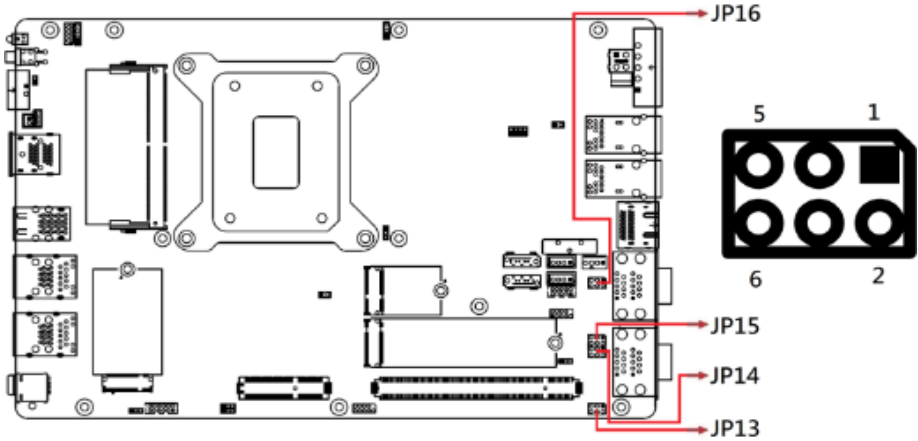

	Setting	Function
	Pin 1-3, Short/Closed	+12V
	Pin 3-4, Short/Closed	RI (Default)
	Pin 3-5, Short/Closed	+5V

2.4.8 JP12: ATX/AT Select

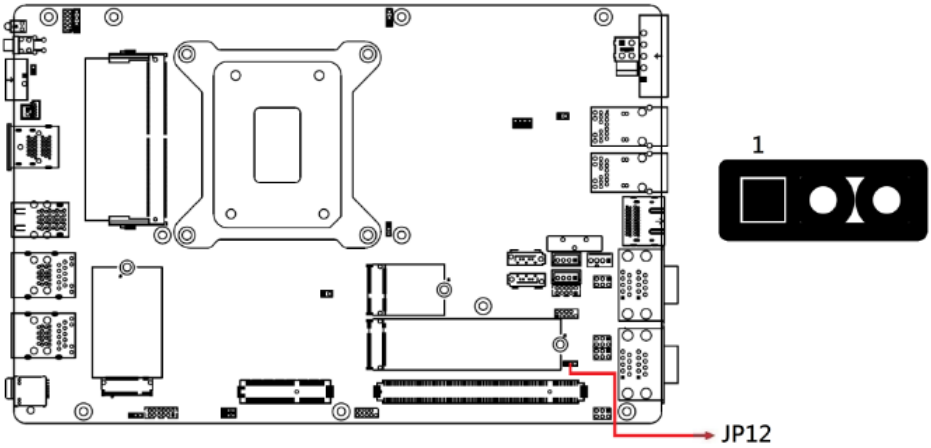

Function	Pin closed	Illustration
ATX (default)	1-2	
AT	2-3	

2.5 Connectors Quick Reference

Function	Connector	Page
Reset Button Connector	J1	35
M.2 B-Key 3052 Slot	J3	35
Audio Connector	J5	36
SPI Flash Connector	J6	36
M.2 M-Key M2280 Slot	J7	37
Factory use only	J8	37
M.2 E-Key E2230 Slot	J9	38
SATA Power Connector	J11, J12	38
DDR5 Memory Sockets	J4, J17	39
80 Port Debug (Factory use only)	J13	39
Digital I/O Connector	J14	40
DC-in Connector	J15	40
DC-in Connector	J16	41
HDD LED	LED1	41
CN13 PoE LED	LED3	42
CN12 PoE LED	LED4	42
Power On Button	SW1	42
Nano SIM card 2, Nano SIM card 1 Slot	CN1, CN14	43
2.5 Gigabit LAN (Intel I226-V) + USB 3.2	CN2	43
2.5 Gigabit LAN (Intel I226-LM) + USB 3.2	CN3	43
USB 3.2 Connector	CN4	44
HDMI Port X2	CN5	44
Power Button Connector	CN6	45
SATA III Connector	CN8, CN7	45
COM3 & COM4 RS-232 Ports	CN9	46
COM1 & COM2 RS-232/422/485 Ports	CN10	47
DisplayPort	CN11	48
Gigabit LAN (Intel I210IT) + PoE+	CN12	48
Gigabit LAN (Intel I210IT) + PoE+	CN13	48
PCI-E x1, USB 2.0 Sys_Fan, SATA, COM TX/RX Signal	PCIE1	49
PCI-E-E x16 Connector	PCIE2	49

2.5.1 J1: Reset Button Connector (Techbest 01017021001-L)

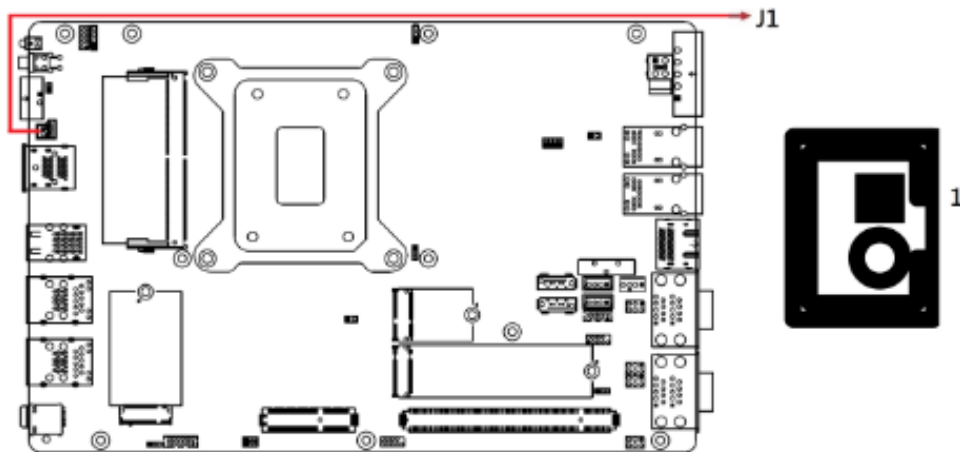

Pin	Signal Name
1	Ground
2	Reset BTN

2.5.2 J3: M.2 B-Key 3052 Slot

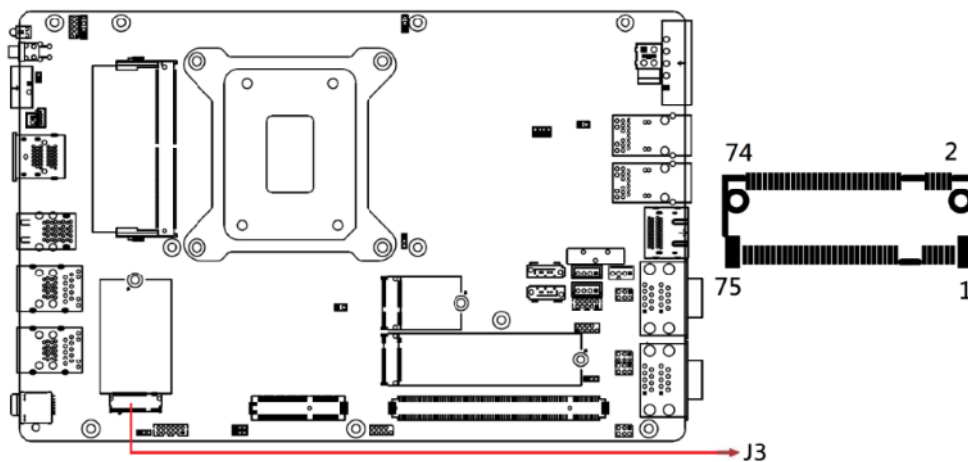

Note: J3 supports PCIe(1x) + USB 3.2 for 5G Sierra EM9191 5G modules

2.5.3 J5: Audio Connector

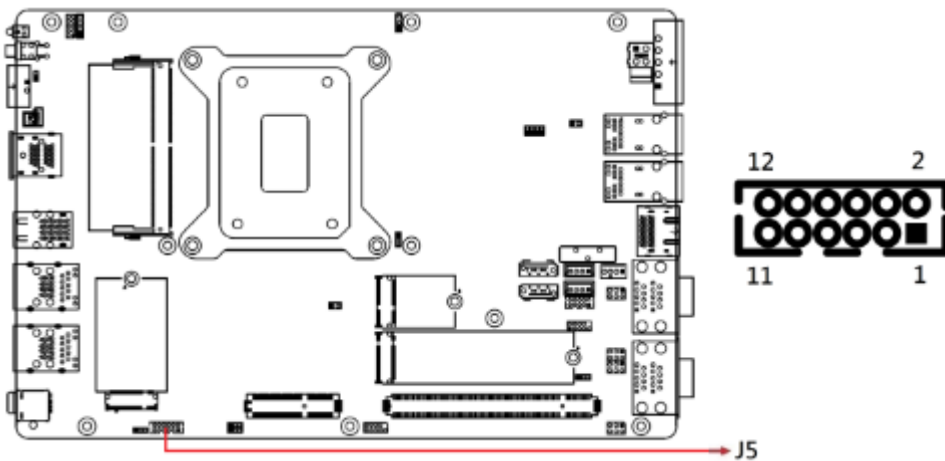

Pin	Assignment	Pin	Assignment
1	LINE OUT_L	2	LINE OUT_R
3	LINE OUT_Sense	4	Ground
5	LINE_L	6	LINE_R
7	LINE_Sense	8	Ground
9	MIC IN_L	10	MIC IN_R
11	MIC_Sense	12	Ground

2.5.4 J6: SPI Flash Connector

Note: J6 is for factory use only.

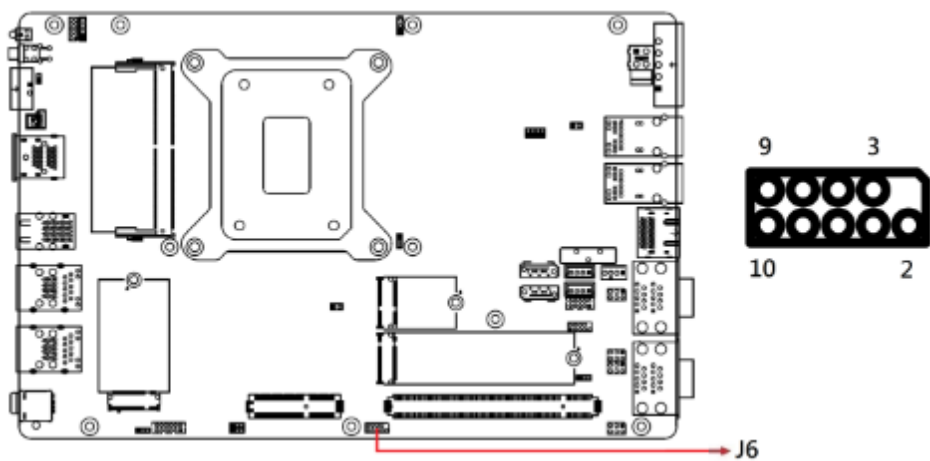

2.5.5 J7: M.2 M-Key M2280 Slot

Note: J7 supports NVME/SATA.

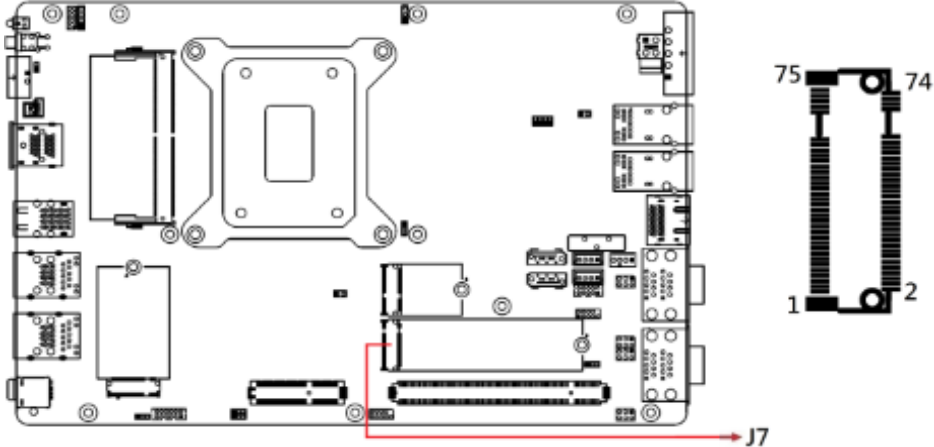

2.5.6 J8: Factory use only

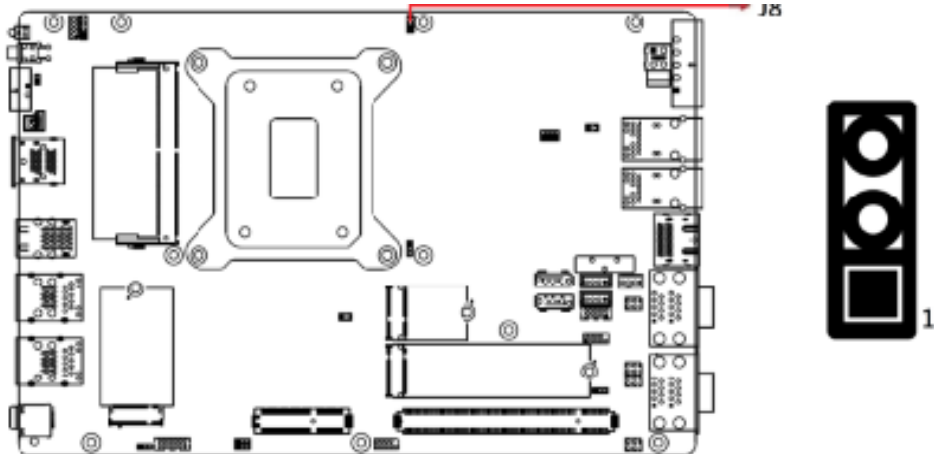

2.5.7 J9: M.2 E-Key E2230 Slot

Note: J9 supports CNVi / PCIe(1x) / USB2.0

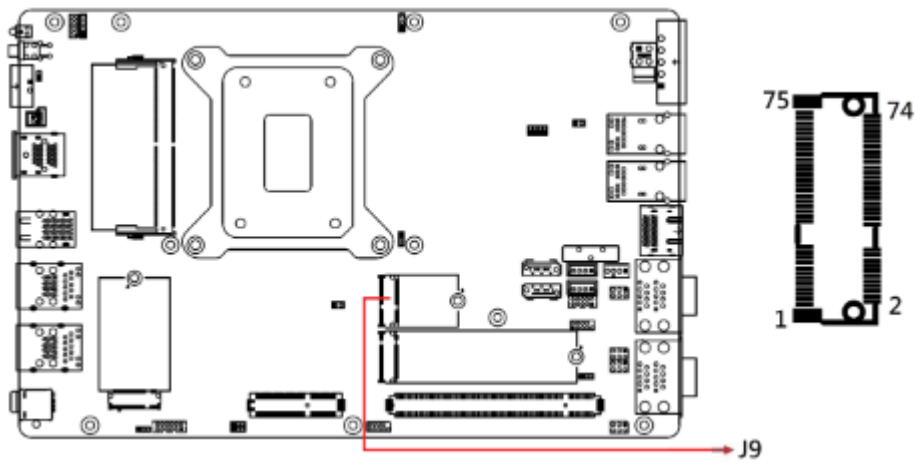

2.5.8 J11, J12: SATA Power Connector

Note: (JST_B4B-XH-A → Compatible Mating JST_XHP-4)

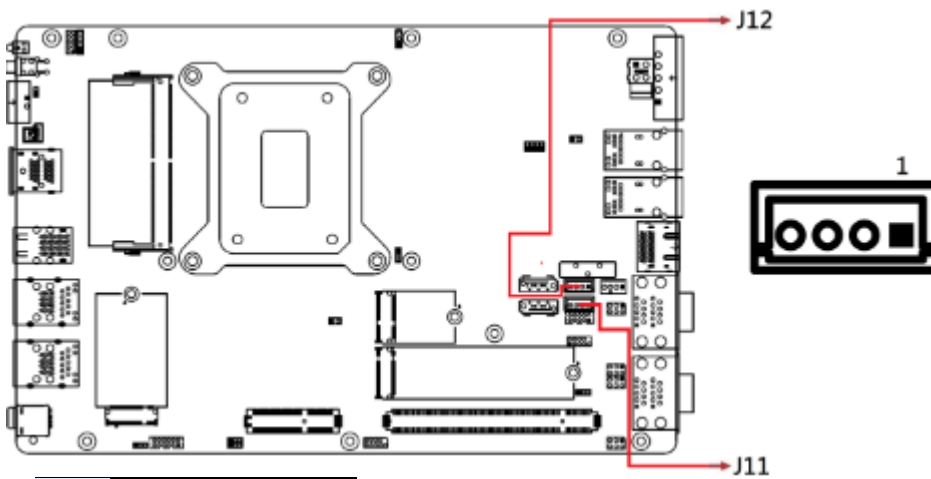

Pin	Signal Name
1	+5V
2	Ground
3	Ground
4	+12V

2.5.9 J4, J17: DDR5 Memory Sockets

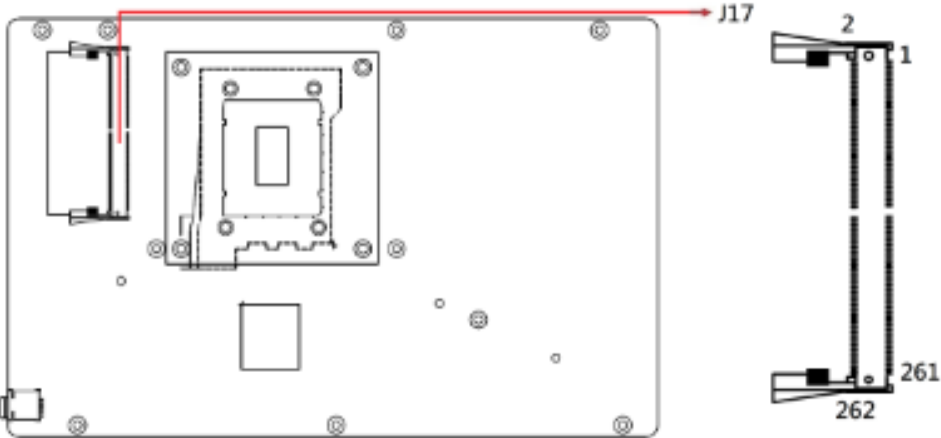
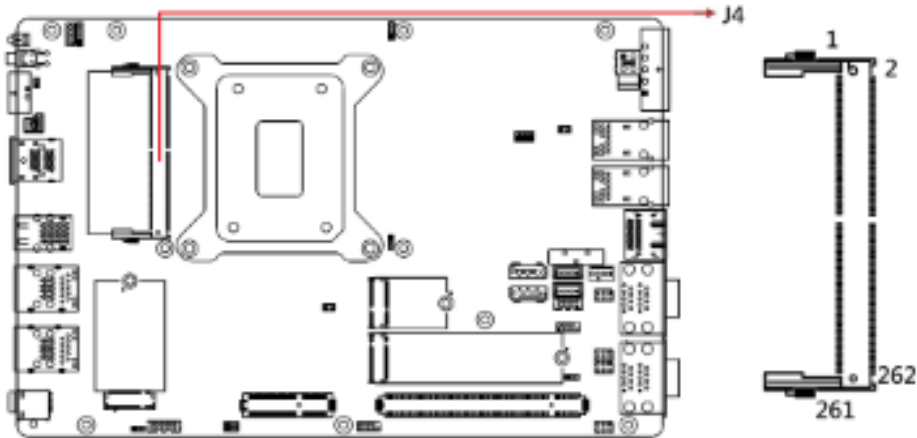

2.5.10 J13: 80 Port Debug (Factory use only)

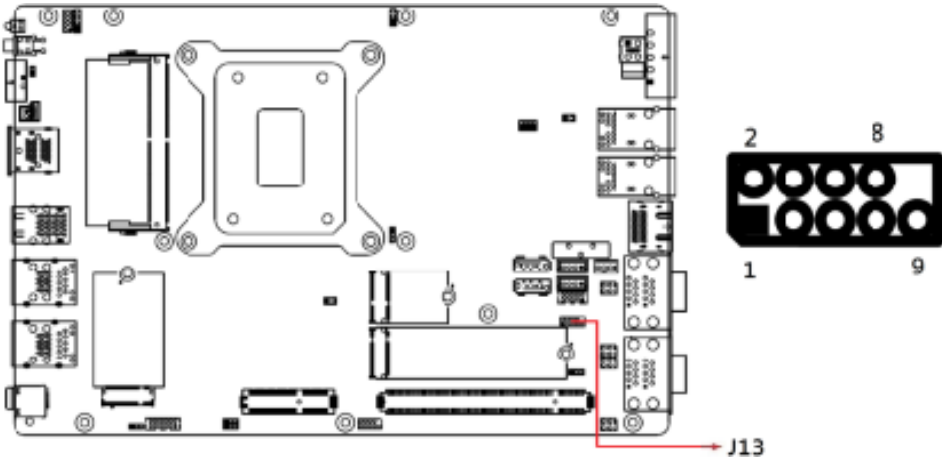

2.5.11 J14: Digital I/O Connector

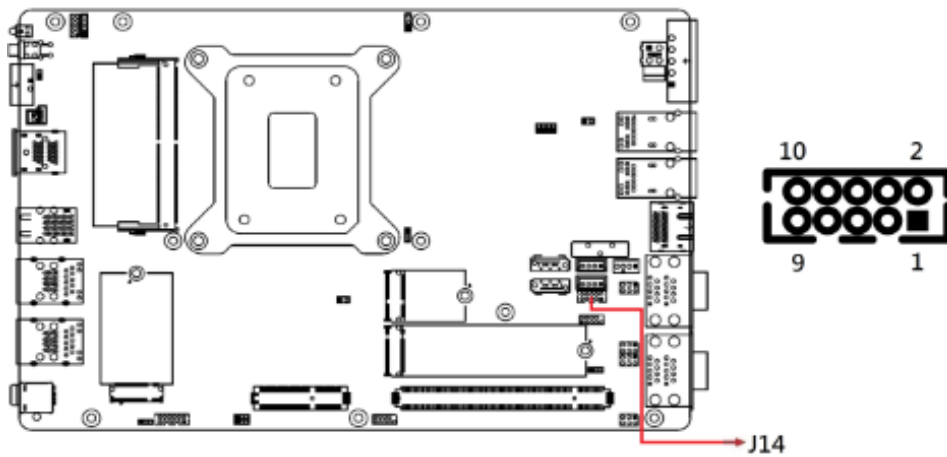

Note: DF11-10S-PA66H HRS Compatible Mating DF11-10DS-2C

Pin	Signal Name	Pin	Signal Name
1	Ground	2	+5V(0.5A)
3	OUT3	4	OUT1
5	OUT2	6	OUT0
7	IN3	8	IN1
9	IN2	10	IN0

2.5.12 J15: DC-in Connector

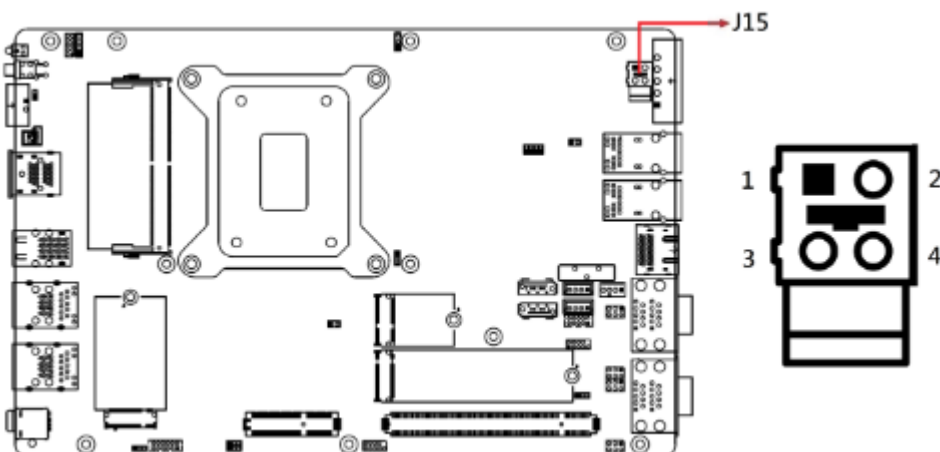

Pin	Signal Name
1	Power Ground
2	Case Ground
3	+24V
4	+24V

2.5.13 J16: DC-in Connector (Dinkle 5EHDRM-05P)

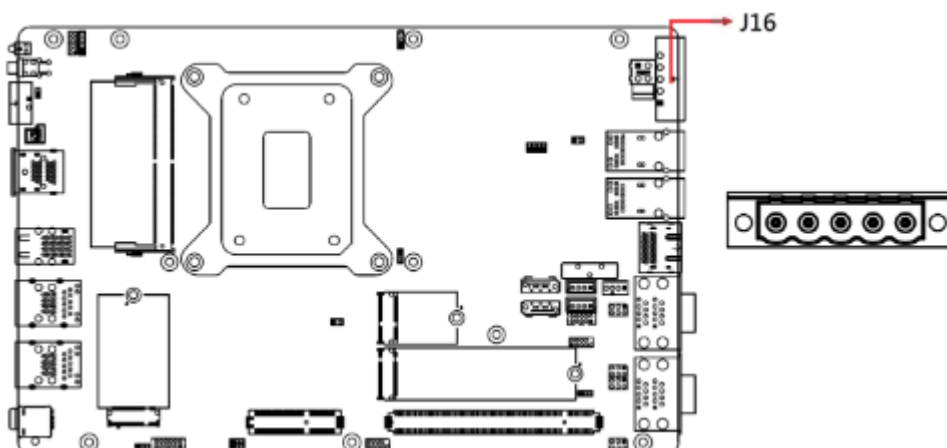

Pin	Signal Name
1	+24V
2	+24V
3	Case Ground
4	Power Ground
5	Power Ground

2.5.14 LED1 : HDD LED

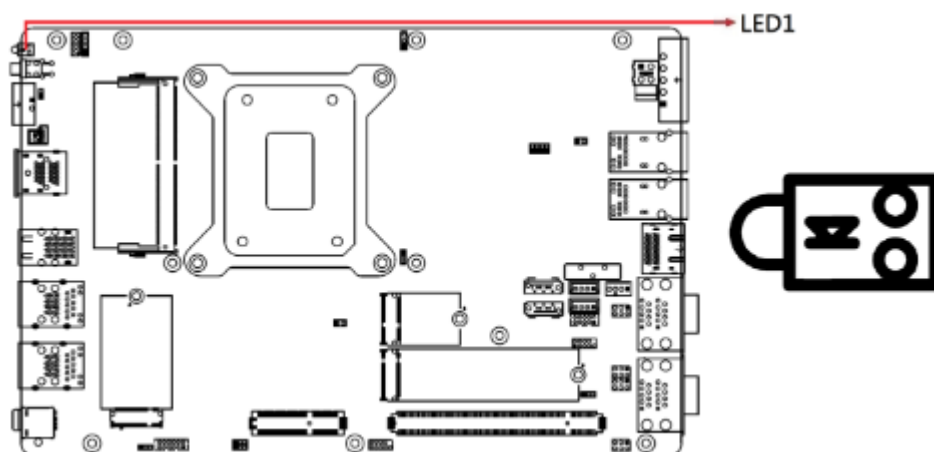

2.5.15 LED3: CN13 PoE LED

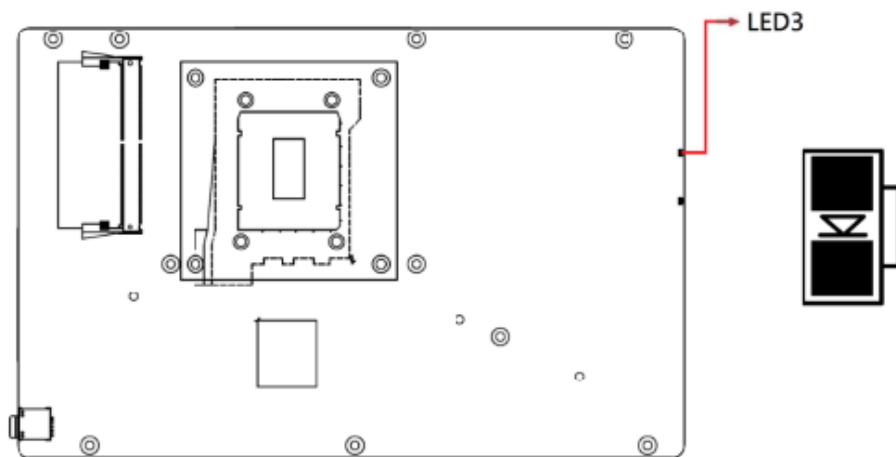

2.5.16 LED4: CN12 PoE LED

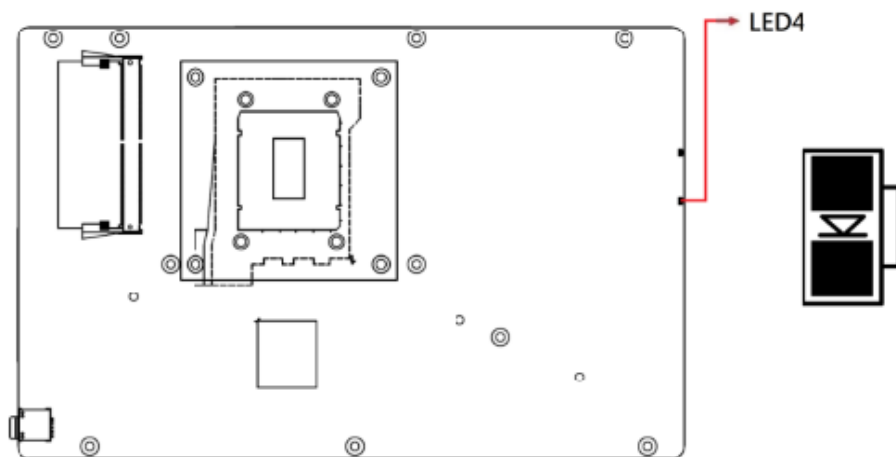

2.5.17 SW1: Power On Button

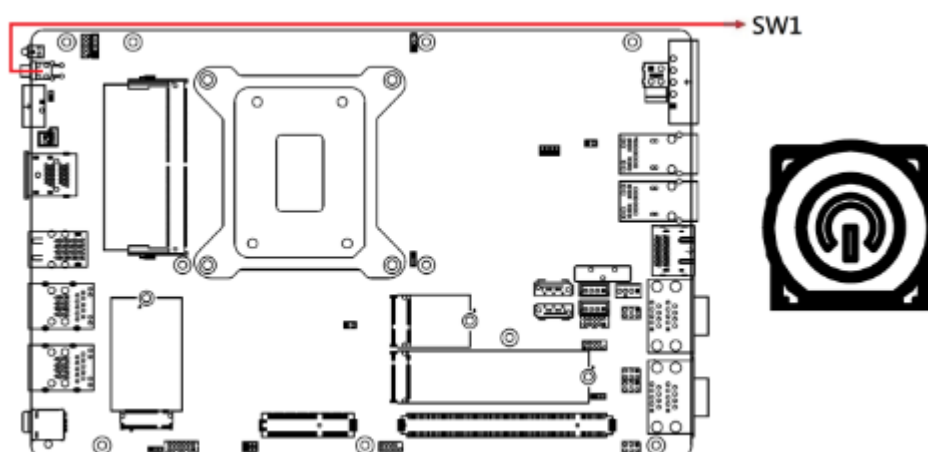

2.5.18 CN1, CN14 : Nano SIM card 2, Nano SIM card 1 Slot

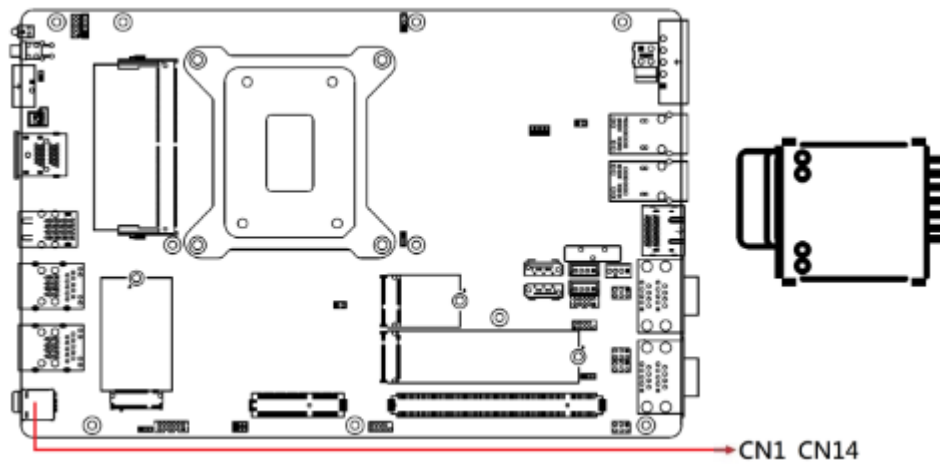

2.5.19 CN2: 2.5 Gigabit LAN (Intel I226-V) + USB 3.2

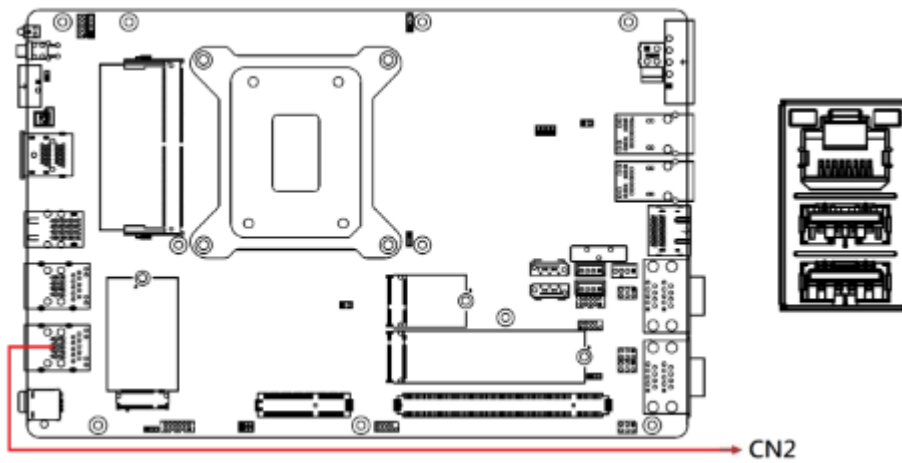

2.5.20 CN3: 2.5 Gigabit LAN (Intel I226-LM) + USB 3.2

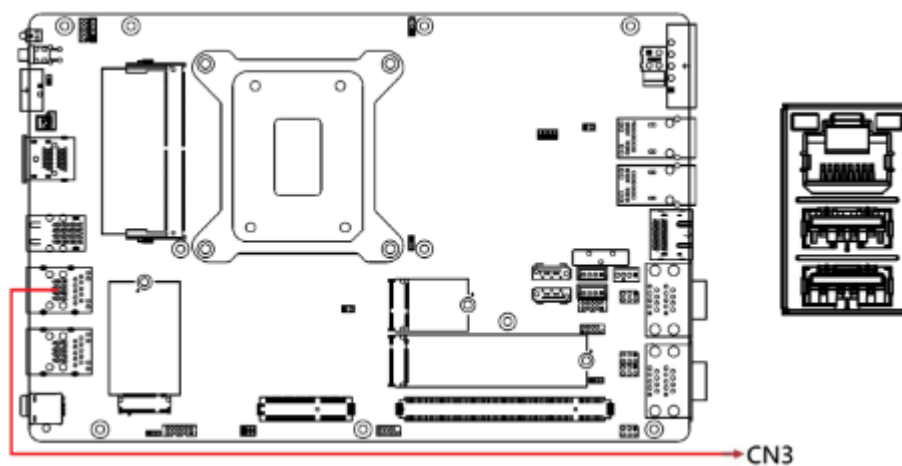

2.5.21 CN4: USB 3.2 Connector

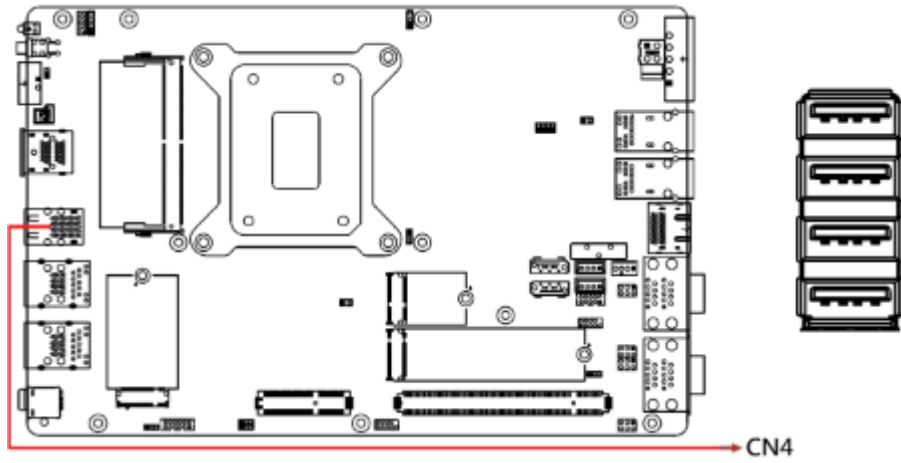

2.5.22 CN5: HDMI Port x2

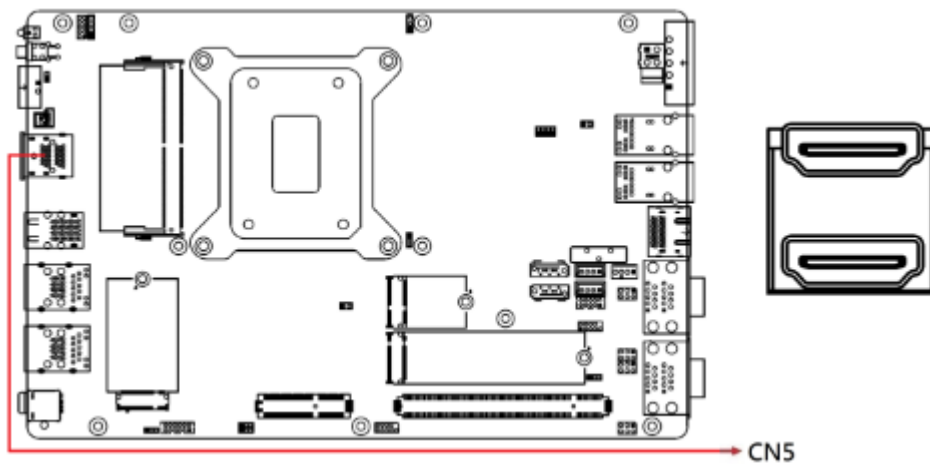

2.5.23 CN6: Power Button Connector (Dinkle ECH350RM-02P)

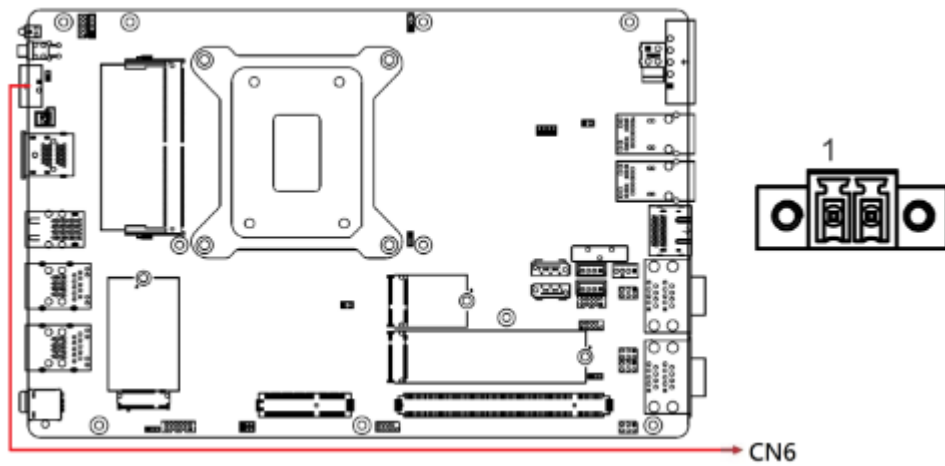

Pin	Signal Name
1	Power BTN
2	Ground

2.5.24 CN8, CN7: SATA III Connectors

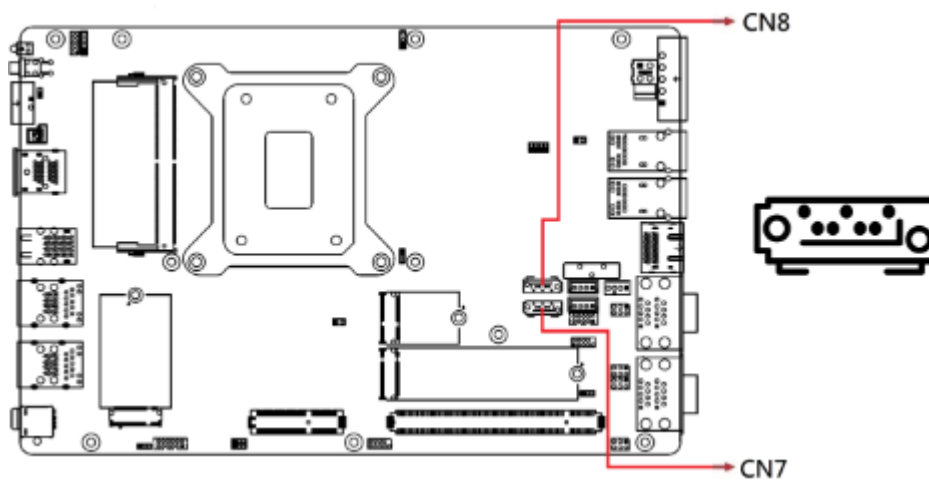

2.5.25 CN9: COM3 & COM4 RS-232 Ports

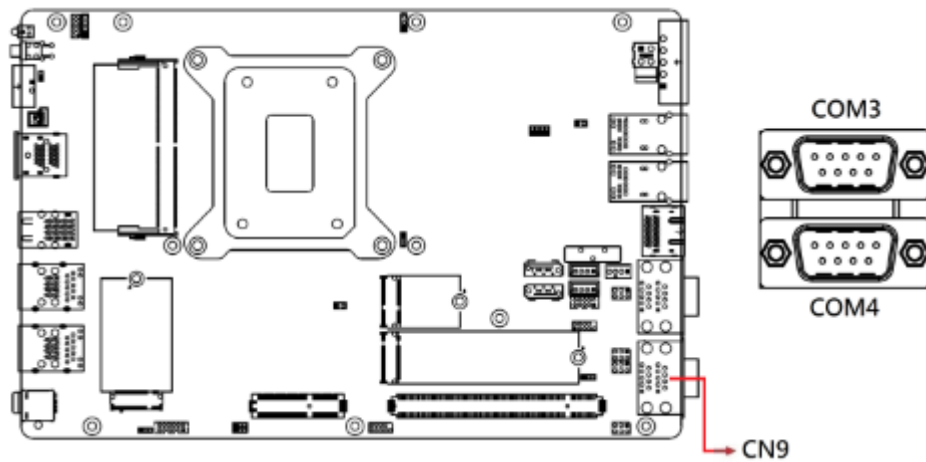

Pin	Signal Name	Pin	Signal Name
1	DCD, Data carrier detect	6	DSR, Data set ready
2	RXD, Receive data	7	RTS, Request to send
3	TXD, Transmit data	8	CTS, Clear to send
4	DTR, Data terminal ready	9	RI, Ring indicator
5	Ground		

2.5.26 CN10: COM1 & COM2 RS-232/422/485 Ports

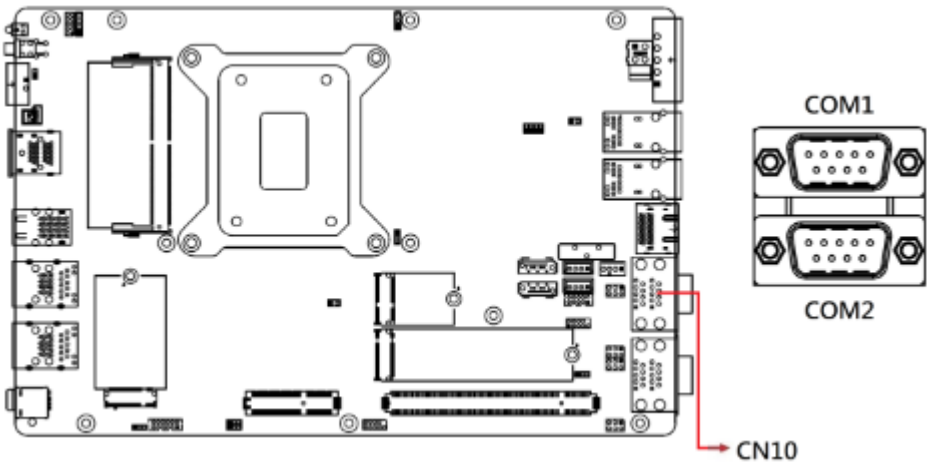

Pin	Signal Name	Pin	Signal Name
1	DCD, Data carrier detect	6	DSR, Data set ready
2	RXD, Receive data	7	RTS, Request to send
3	TXD, Transmit data	8	CTS, Clear to send
4	DTR, Data terminal ready	9	RI, Ring indicator
5	Ground		

COM1/COM2 RS-232/422/485 are jumperless, configurable in BIOS.

Pin	Signal Name		
	RS-232	RS-422	RS-485
1	DCD	TX-	DATA-
2	RX	TX+	DATA+
3	TX	RX+	NC
4	DTR	RX-	NC
5	Ground	Ground	Ground
6	DSR	NC	NC
7	RTS	NC	NC
8	CTS	NC	NC
9	RI	NC	NC

2.5.27 CN11: DisplayPort x2

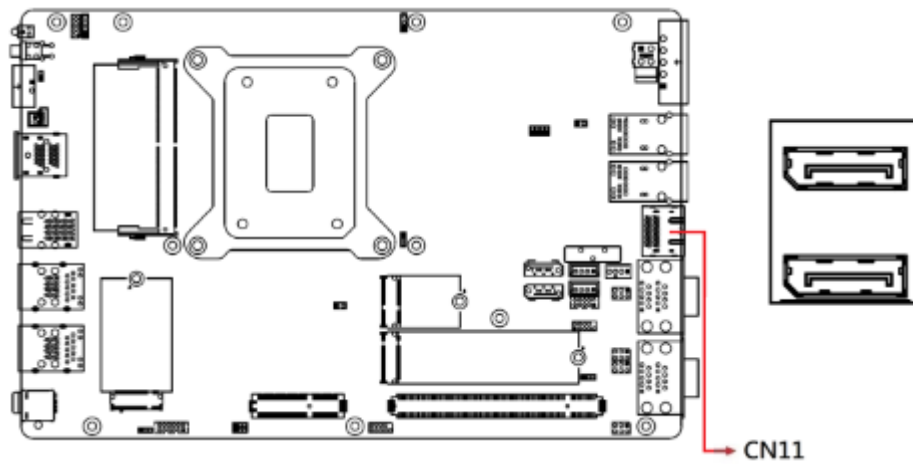

2.5.28 CN12: Gigabit LAN (Intel I210IT) + PoE+

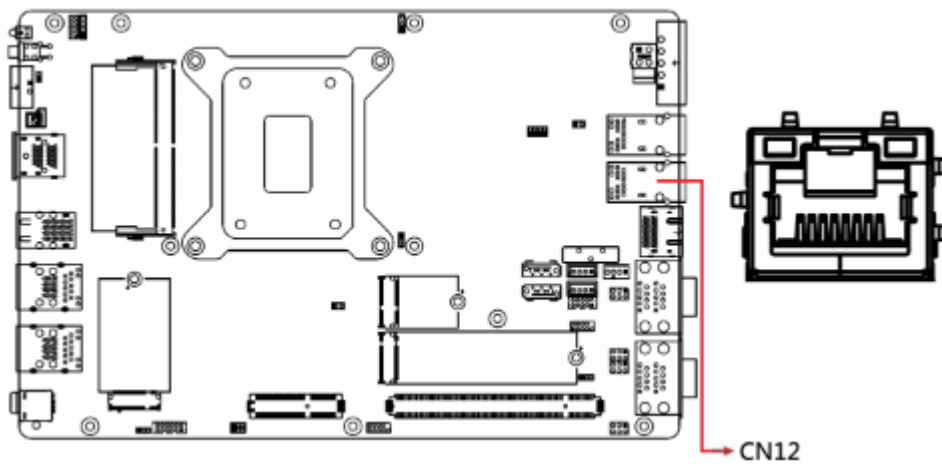

2.5.29 CN13: Gigabit LAN (Intel I210IT) + PoE+

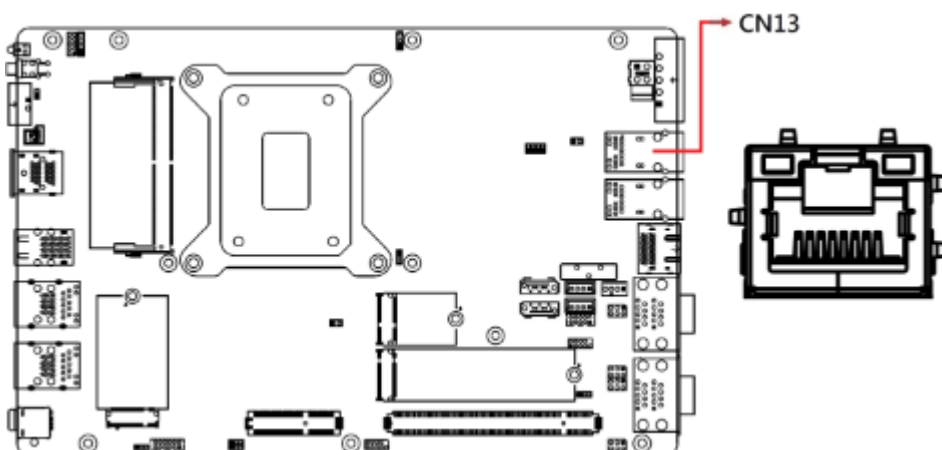

2.5.30 PCIE1: For PCI-E x1, USB 2.0 Sys_Fan, SATA, COM TX/RX Signal

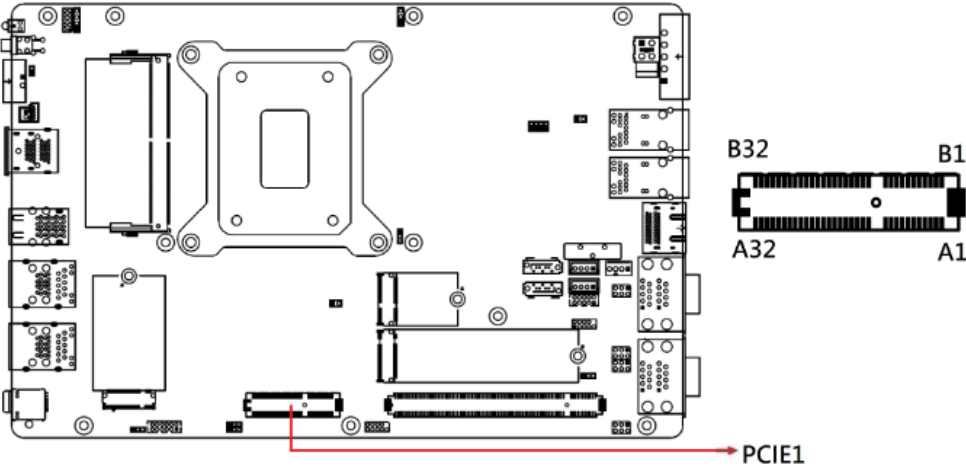

2.5.31 PCIE2: PCI-E x16 Connector

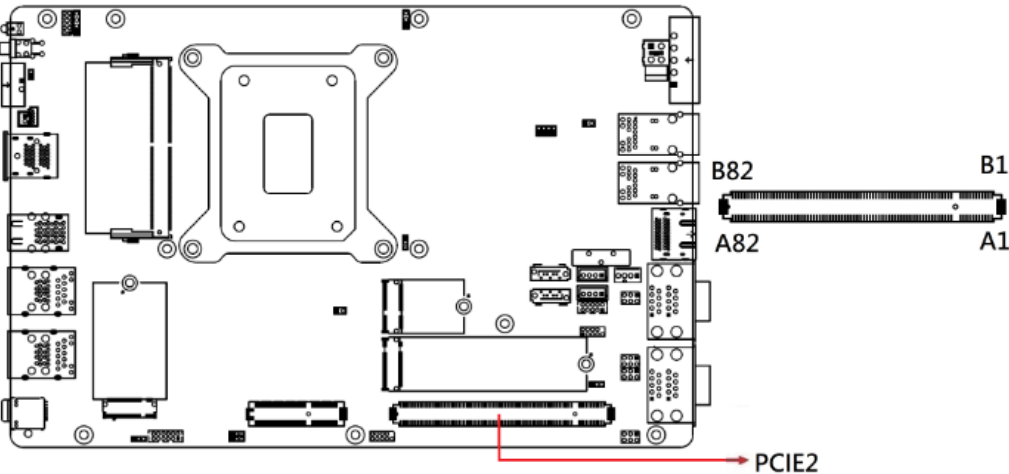

Chapter 3

Driver Installation

The information provided in this chapter includes:

- Intel® Chipset Software Installation Utility
- Graphics Driver Installation
- HD Audio Driver Installation
- LAN Drivers Installation
- Intel® Management Engine Drivers Installation
- Intel® Serial IO Drivers Installation

3.1 Introduction

This section describes the installation procedures for software drivers.

Note: After installing your Windows operating system, install the Intel® Chipset Software Installation Utility before proceeding with drivers installation.

3.2 Intel® Chipset Software Installation Utility

Before installing any software drivers, start with the Intel® Chipset drivers to ensure the operating system can effectively manage the motherboard's chipset components for optimal Plug & Play functionality.

1. Go to the download page of the product. Copy the compressed drivers file to your computer. Double click the file to decompress it. Run "CDGuide" to go to the main drivers page as shown. Click **Intel** on the left pane and then **Intel(R) AlderLake-S/RaptorLake-S Chipset Drivers**, and **Intel(R) Chipset Software Installation Utility** on the right pane.





2. When the *Welcome* screen to the Intel® Chipset Device Software appears, click **Next** to continue.

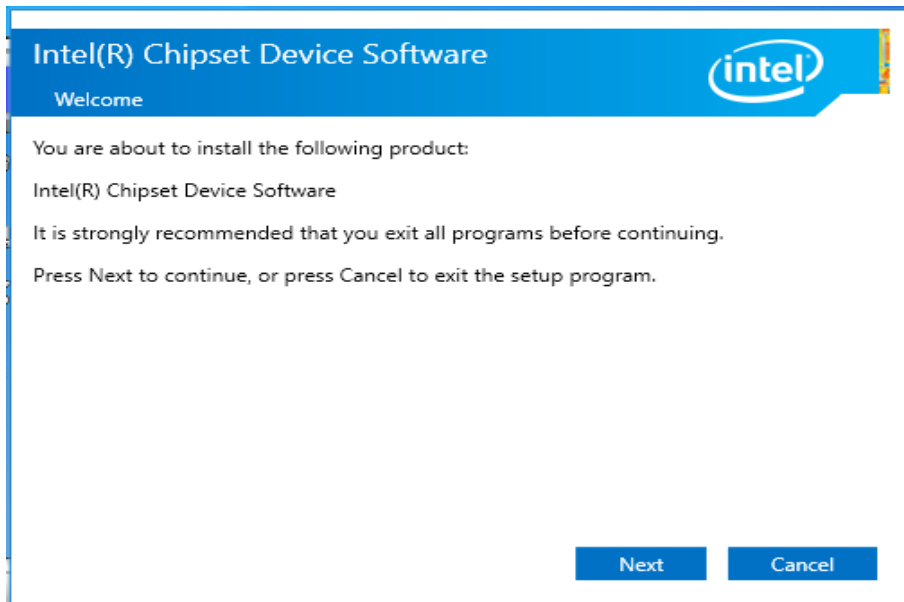

3. Accept the *License Agreement* and click **Accept**.
4. On the *Readme File Information* screen, click **Install**.
5. When the driver has been completely installed, click **Finish** to complete the setup process.

3.3 Graphics Driver Installation

1. Click **Intel** on the left pane and then **Intel(R) AlderLake-S/ RaptorLake-S Chipset Drivers**, and **Intel(R) HD Graphics Driver** on the right pane.



2. When the **Intel Graphics Driver Installer** screen appears, click **Begin installation**.



3. Click **I agree** to accept the INTEL SOFTWARE LICENSE AGREEMENT.
4. In the Pre-Install stage, “The installer will install the following components:
 - Intel® Graphics Driver
 - Intel® Graphics Command CenterClick **Start** to start installing the new graphics driver.
5. The next screen will indicate that the new graphics driver is being installed. When the message “**Installation complete!**” appears, restart your system in order to apply the driver changes.

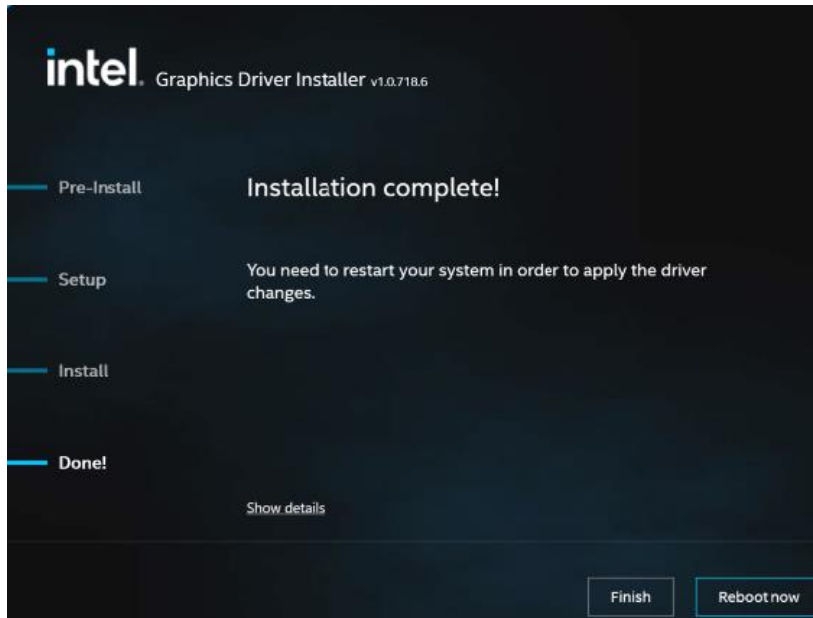

3.4 HD Audio Driver Installation

1. Click **Intel** on the left pane and then **Intel(R) AlderLake-S/ RaptorLake-S Chipset Drivers**, and **Realtek High Definition Audio Driver** on the right pane.



2. On the Welcome screen of the InstallShield Wizard, click **Next** to install the driver.

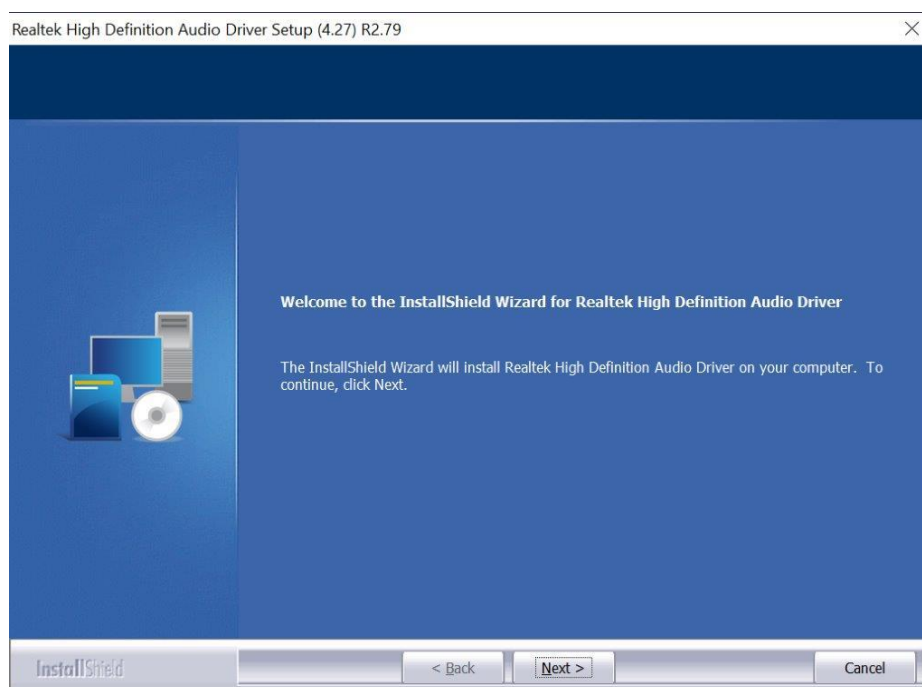

3. When the audio driver has been successfully, click **Finish** to restart the computer.

3.5 LAN Drivers Installation

1. Click **LAN Card** on the left pane and then **Intel PRO LAN Network Drivers** on the right pane.

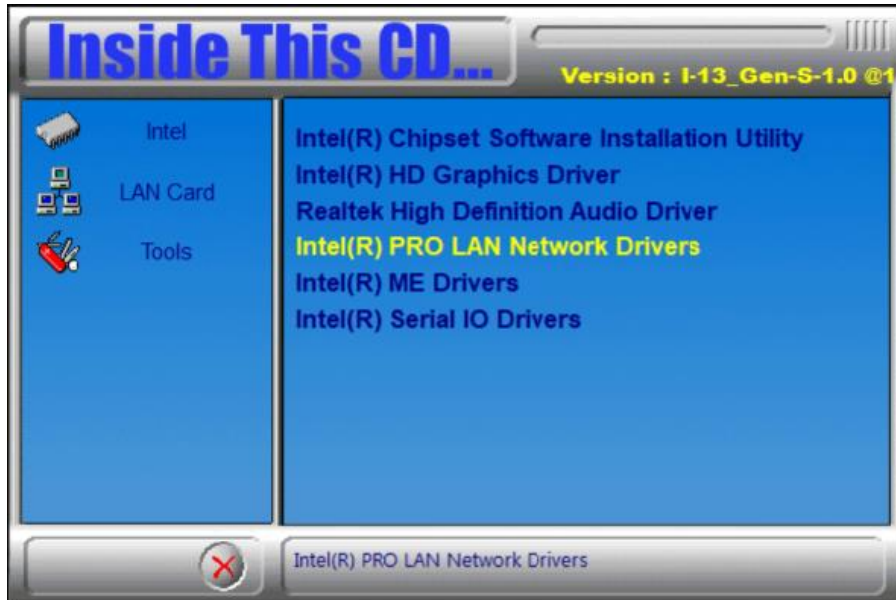

2. Click **Intel Drivers and Software**.

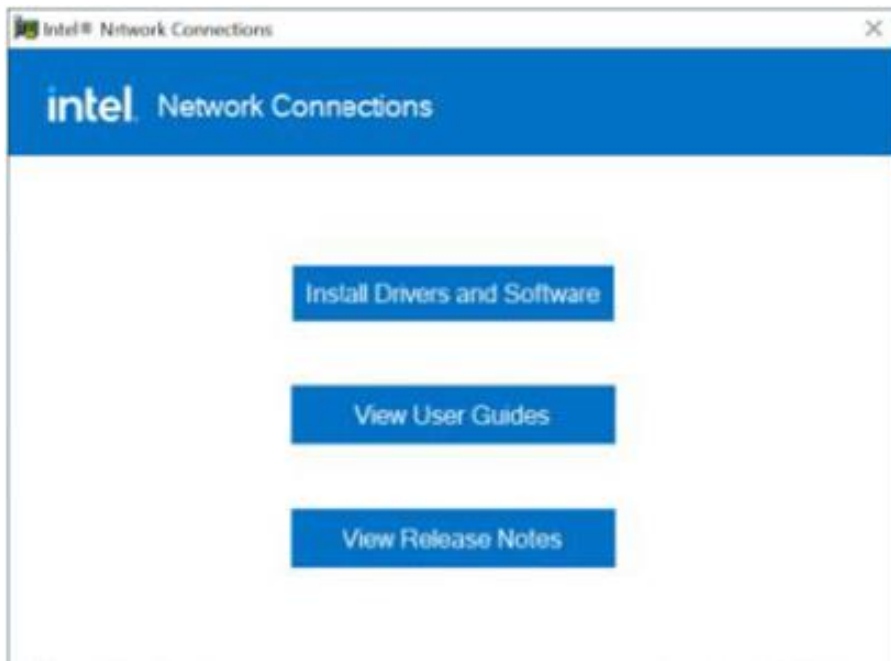

3. When the Welcome to the install wizard for Intel(R) Network Connection screen appears, click **Next**. On the next screen, accept the terms in the License Agreement and click **Next**.
4. On the Setup Options screen, select the program features you want installed. Then click **Next** to continue.

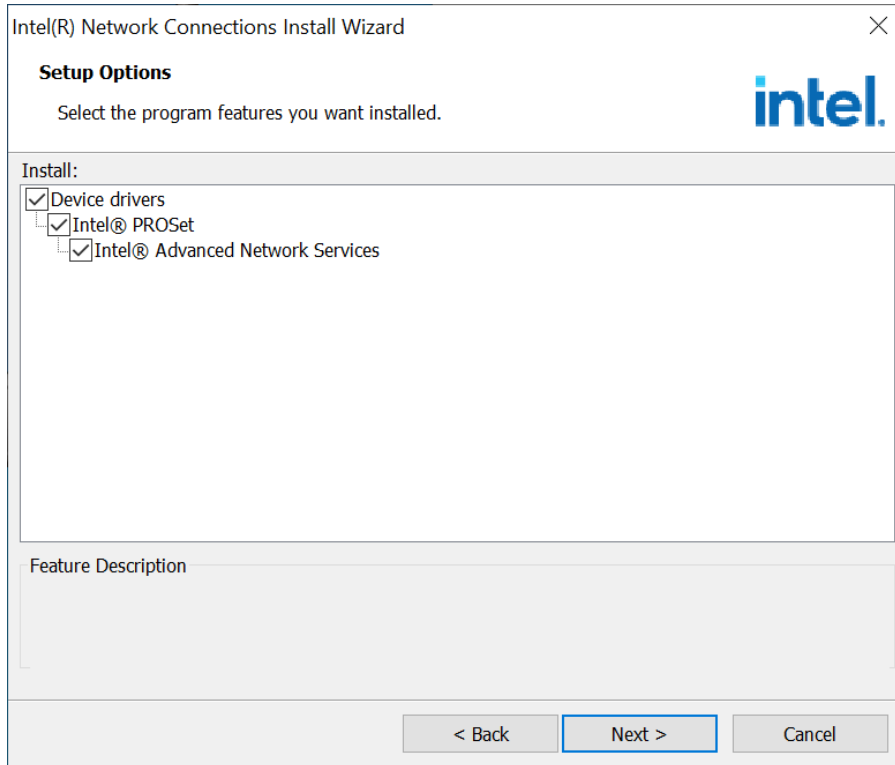

5. On the Ready to Install the Program screen, click **Install** to begin the installation.
6. When the Install wizard Completed screen appears, click **Finish**.

3.6 Intel® Management Engine Driver Installation

1. Click **Intel** on the left pane and then **Intel(R) AlderLake-S/ RaptorLake-S Chipset Drivers**, and **Intel(R) ME Drivers** on the right pane.



2. When the Welcome screen to the Intel® Management Engine Components appears, click **Next**.
3. Accept the terms in the License Agreement and click **Next**.
4. On the next screen, click **Next** to install to the default folder.
5. Click **Finish** when the necessary components have been successfully installed.

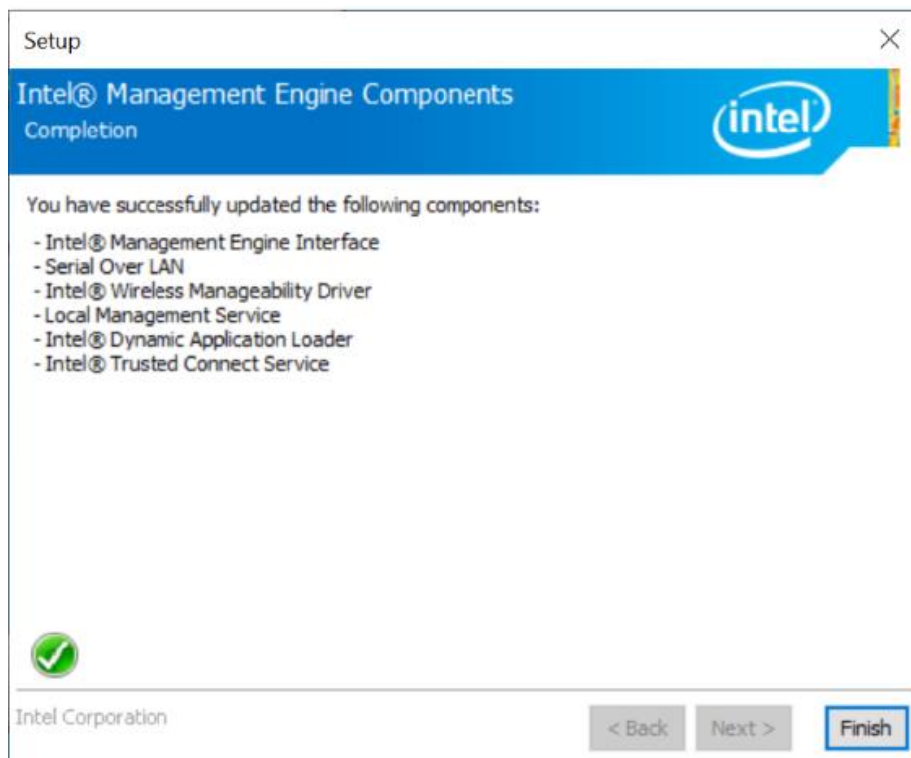

3.7 Intel® Serial IO Drivers Installation

1. Click **Intel** on the left pane and then **Intel(R) AlderLake-S/ RaptorLake-S Chipset Drivers**, and **Intel(R) Serial IO Drivers** on the right pane.



2. When the Welcome screen to the Intel® Serial IO appears, click **Next**.

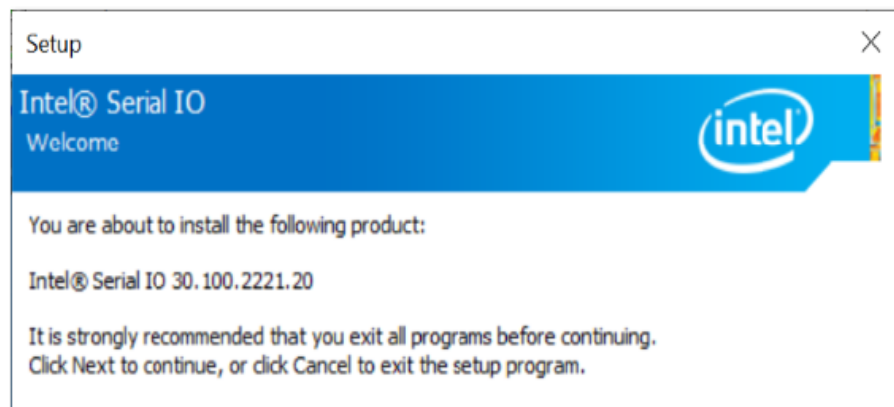

3. Accept the terms in the license agreement and click **Next**.
4. On the Readme File Information and Confirmation screens, click **Next**.
5. Click **Finish** when the Completion screen appears.

Chapter 4

BIOS Setup

This chapter describes the different settings available in the AMI BIOS that comes with the board. The topics covered in this chapter are as follows:

- Main Settings
- Advanced Settings
- Chipset Settings
- Security Settings
- Boot Settings
- Save & Exit

4.1 Introduction

The BIOS (Basic Input/Output System) installed in the ROM of your computer system supports Intel® processors. The BIOS provides critical low-level support for standard devices such as disk drives, serial ports and parallel ports. It also provides password protection as well as special support for detailed fine-tuning of the chipset controlling the entire system.

4.2 BIOS Setup

The BIOS provides a Setup utility program for specifying the system configurations and settings. The BIOS ROM of the system stores the Setup utility. When you turn on the computer, the BIOS is immediately activated. Press the key immediately allows you to enter the Setup utility. If you are a little bit late pressing the key, POST (Power On Self Test) will continue with its test routines, thus preventing you from invoking the Setup. You can also press <F7> to call the pop-up Boot menu immediately.

If you still need to enter Setup, restart the system by pressing the "Reset" button or simultaneously pressing the <Ctrl>, <Alt> and <Delete> keys. You can also restart by turning the system Off and back On again.

The following message will appear on the screen:

```
Press <DEL> to Enter Setup
```

In general, press the arrow keys to highlight items, <Enter> to select, the <PgUp> and <PgDn> keys to change entries, <F1> for help, and <Esc> to quit.

When you enter the BIOS Setup utility, the *Main Menu* screen will appear on the screen. The Main Menu allows you to select from various setup functions and exit choices.

Warning: It is strongly recommended that you avoid making any changes to the chipset defaults.

These defaults have been carefully chosen by both AMI and your system manufacturer to provide the absolute maximum performance and reliability. Changing the defaults could make the system unstable and crash in some cases.

4.3 Main Settings



BIOS Setting	Description
System Language	Choose the system default language.
System Date	Sets the date. Use the <Tab> key to switch between the date elements.
System Time	Set the time. Use the <Tab> key to switch between the time elements.

4.4 Advanced Settings

This section allows you to configure, improve your system and to set up some system features according to your preference.

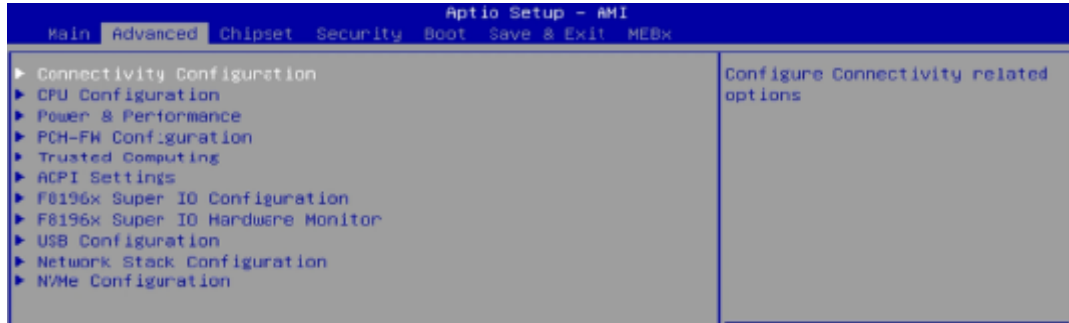

4.4.1 Connectivity Configuration



BIOS Setting	Description
CNVi Mode	This option configures Connectivity. [Auto Detection] means that if discrete solution is discovered it will be enabled by default. Otherwise, integrated solution (CNVi) will be enabled; [Disable Integrated] disables Integrated Solution.
BT Audio Offload	This is an option to enable/disable BT audio offload which enables audio DSP and enables power efficient audio output to BT device.
RFI Mitigation	This is an option intended to enable/disable DDR-RFIM feature for connectivity. This RFI mitigation feature may result in temporary slowdown of the DDR speed.
CoExistence Manager	CoEx Manager mitigates radio coexistence issues between Intel WWAN (modem) and Intel WLAN (WiFi/BT). This should be enabled only if both WWAN and WLAN solutions are based on Intel components.
Preboot BLE	This will be used to enable Preboot Bluetooth function.

Discrete Bluetooth Module	Seriallo UART0 needs to be enabled to select BT module.
BT Tile Mode	Enable/Disable Tile
Advanced Settings	Configure ACPI objects for wireless devices
WWAN Device	Select the M.2 WWAN Device options to enable 4G – 7360/7560 (Intel) 5G – MediaTek Modems

4.4.2 CPU Configuration



BIOS Setting	Description
Intel (VMX) Virtualization Technology	When enabled, a VMM can utilize the additional hardware capabilities provided by Vanderpool Technology.
Active Processor Cores	Number of cores to enable in each processor package. Note: Number of Cores and E-cores are looked at together. When both are (0,0), Pcode will enable all cores. Options: All, 3, 2, 1
Hyper-Threading	Enable or Disable Hyper-Threading Technology.
Legacy Game Compatibility Mode	When enable, pressing the scroll lock key will toggle the Efficient-cores between being parked with scroll lock LED is on and un-parked when LED is off.

4.4.3 Power & Performance

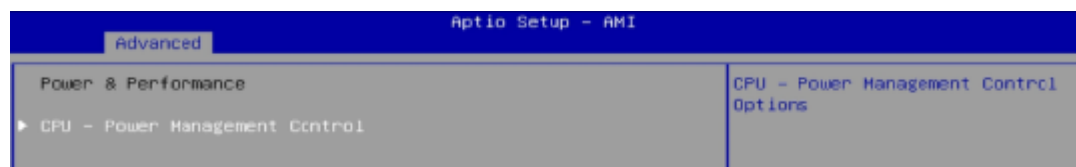

BIOS Setting	Description
CPU – Power Management Control	CPU – Power Management Control Options
Intel(R) SpeedStep(tm)	Willows more than two frequency ranges to be supported.
Intel(R) Speed Shift Technology	Enable/Disable Intel(R) Speed Shift Technology support. Enabling will expose the CPPC v2 interface to allow for hardware controlled P-states.
Turbo Mode	Enable/Disable processor turbo mode (requires EMTTM enabled too). AUTO means enabled.

4.4.4 PCH-FN Configuration

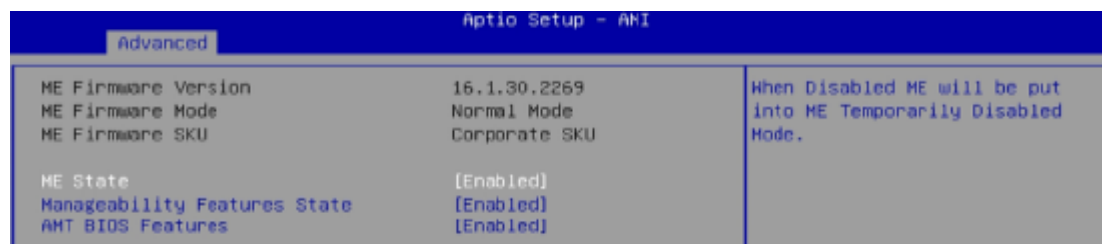

BIOS Setting	Description
ME State	When Disabled, ME will be put into ME Temporarily Disabled Mode.
Manageability Features State	Enable/Disable Intel(R) manageability features. Note: This option disables/enables manageability features support in FW. To disable support platform must be in an unprovisioned state first.
AMI BIOS Features	When disabled AMT BIOS Features are no longer supported and user is no longer able to access MEBx Setup. Note: This option does not disable Manageability Features in FW.

4.4.5 Trusted Computing



BIOS Setting	Description
Security Device Support	Enables / Disables BIOS support for security device. OS will not show security device. TCG EFI protocol and INTIA interface will not be available.
SHA256 PCR Bank	Enable or Disable SHA256 PCR Bank
Pending operation	Schedule an operation for the security device. NOTE: Your computer will reboot during restart in order to change state of security device.
Platform Hierarchy	Enable or Disable Platform Hierarchy
Storage Hierarchy	Enable or Disable Storage Hierarchy
Endorsement Hierarchy	Enable or Disable Endorsement Hierarchy
Physical Presence Spec Version	Select to tell OS to support PPI Spec Version 1.2 or 1.3. Note some HCK tests might not support 1.3.
Device Select	TPM 1.2 will restrict support to TPM 1.2 devices. TPM 2.0 will restrict to support TPM 2.0 devices. Auto will support both, with the default set to TPM 2.0 devices. If not found, TPM 1.2 devices will be enumerated.

4.4.6 ACPI Settings

Advanced		Aptio Setup - AMI
ACPI Settings		Enables or Disables BIOS ACPI Auto Configuration.
Enable ACPI Auto Configuration	[Disabled]	
Enable Hibernation	[Enabled]	
ACPI Sleep State	[S3 (Suspend to RAM)]	

BIOS Setting	Description
Enable ACPI Auto Configuration	Enables / Disables BIOS ACPI Auto Configuration.
Enable Hibernation	Enables / Disables the system ability to hibernate (OS/S4 Sleep State). This option may not be effective with some operating systems.
ACPI Sleep State	Selects the highest ACPI sleep state for the system will enter when the SUSPEND button is pressed. Options: Suspend Disabled S3 (Suspend to RAM)

4.4.7 F8196x Super IO Configuration

Aptio Setup - AHI

Advanced

F8196x Super IO Configuration

Super IO Chip: F8196x
Power Failure: [Always off]

- Serial Port 1 Configuration
- Serial Port 2 Configuration
- Serial Port 3 Configuration
- Serial Port 4 Configuration
- Serial Port 5 Configuration
- Serial Port 6 Configuration

Serial Port 1 Configuration

Serial Port: [Enabled]
Device Settings: ID=3F8h; IRQ=4;
Change Settings: [Auto]
Device Mode: [RS232]

Change the Serial Port mode.

Device Mode options:

- RS232
- RS485 TX Low Active
- RS485 with Termination TX Low Active
- RS422
- RS422 with Termination

Select Screen
Select Item

Serial Port 2 Configuration

Serial Port: [Enabled]
Device Settings: ID=2F8h; IRQ=3;
Change Settings: [Auto]
Device Mode: [RS232]

Select an optimal settings for Super IO Device

Change Settings options:

- Auto
- ID=2F8h; IRQ=3;
- ID=3F8h; IRQ=3,4,5,6,7,9,10,11,12;
- ID=2F8h; IRQ=3,4,5,6,7,9,10,11,12;
- ID=3E8h; IRQ=3,4,5,6,7,9,10,11,12;
- ID=2E8h; IRQ=3,4,5,6,7,9,10,11,12;

Select Screen
Select Item

Serial Port 2 Configuration

Serial Port: [Enabled]
Device Settings: ID=2F8h; IRQ=3;
Change Settings: [Auto]
Device Mode: [RS232]

Change the Serial Port mode.

Device Mode options:

- RS232
- RS485 TX Low Active
- RS485 with Termination TX Low Active
- RS422
- RS422 with Termination

Select Screen
Select Item

Serial Port 3 Configuration

Serial Port: [Enabled]
Device Settings: ID=3E8h; IRQ=5;
Change Settings: [Auto]

Select an optimal settings for Super IO Device

Change Settings options:

- Auto
- ID=3E8h; IRQ=5;
- ID=3E8h; IRQ=3,4,5,6,7,9,10,11,12;
- ID=2E8h; IRQ=3,4,5,6,7,9,10,11,12;
- ID=3E0h; IRQ=3,4,5,6,7,9,10,11,12;
- ID=2E0h; IRQ=3,4,5,6,7,9,10,11,12;

Select Screen
Select Item

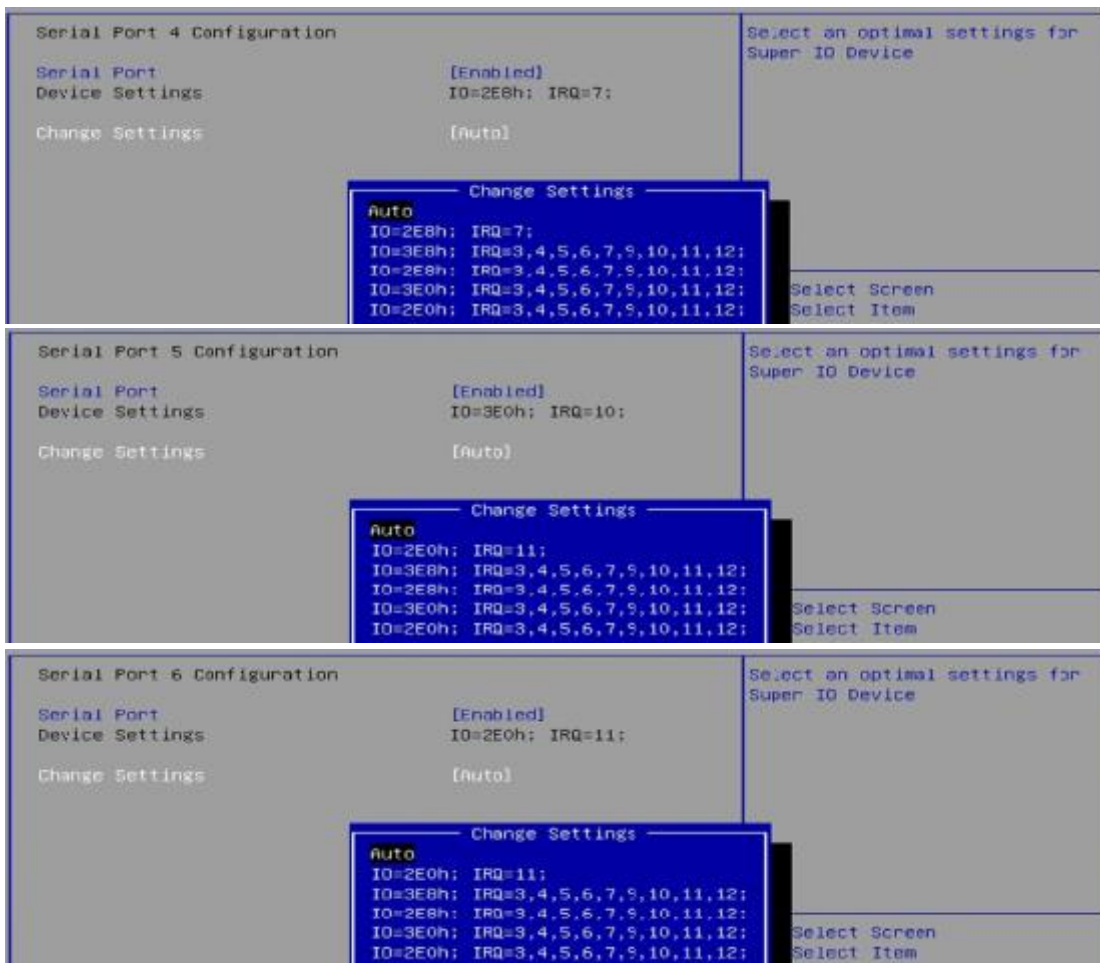

BIOS Setting	Description
Serial Port Configuration	Sets parameters of Serial Ports. Enables / Disables the serial port and select an optimal setting for the Super IO device.
Power Failure	Options: Always on, Always off

4.4.8 F8196x Hardware Monitor

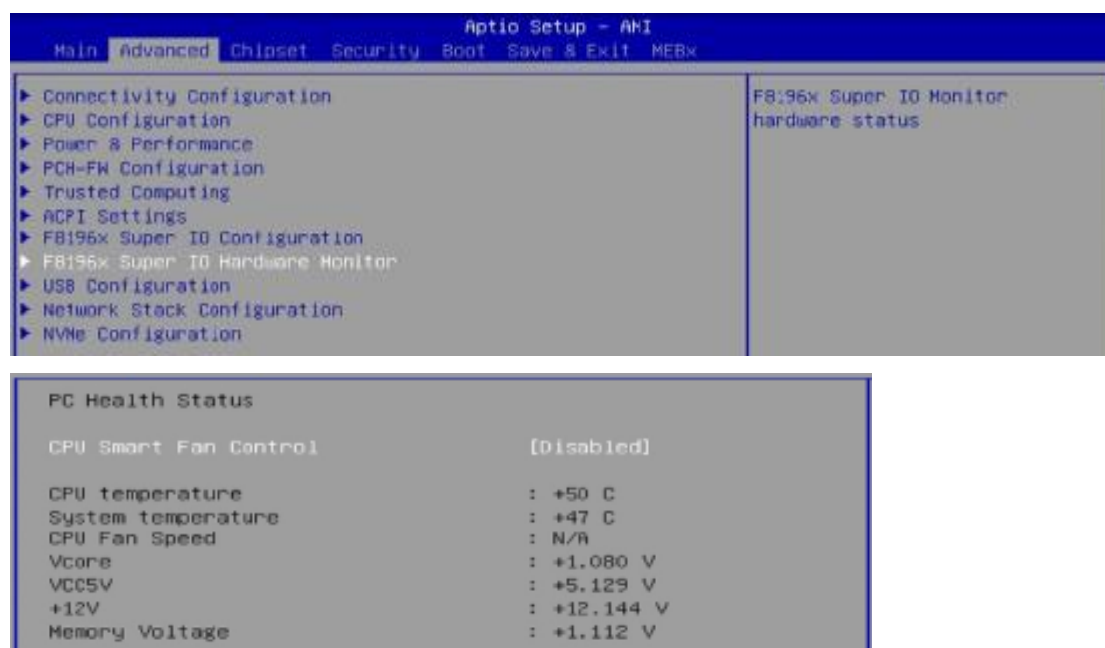

BIOS Setting	Description
CPU Smart Fan Control	Enables / Disables the CPU smart fan feature. Options: Disabled / 50°C / 60°C / 70°C / 80°C
Temperatures / Voltages	These fields are the parameters of the hardware monitoring function feature of the motherboard. The values are read-only values as monitored by the system and show the PC health status.

4.4.9 USB Configuration

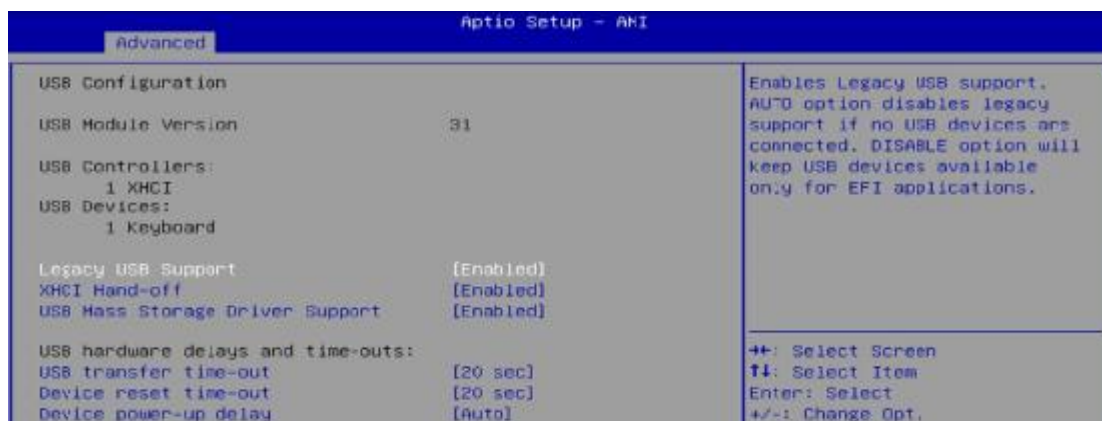

BIOS Setting	Description
Legacy USB Support	Enables Legacy USB support. <ul style="list-style-type: none"> • Auto disables legacy support if there is no USB device connected. • Disable keeps USB devices available only for EFI applications.
XHCI Hand-off	This is a workaround for OSes without XHCI hand-off support. The XHCI ownership change should be claimed by XHCI driver.
USB Mass Storage Driver Support	Enables / Disables the support for USB mass storage driver.
USB Transfer time-out	The time-out value for control, bulk, and Interrupt transfers. Options: 1 sec / 5 sec / 10 sec / 20 sec
Device reset time-out	Seconds of delaying execution of start unit command to USB mass storage device. Options: 10 sec / 20 sec / 30 sec / 40 sec
Device power-up delay	The maximum time the device will take before it properly reports itself to the Host Controller. Auto uses default value for a Root port it is 100ms. But for a Hub port, the delay is taken from Hub descriptor. Options: Auto / Manual

4.4.10 Network Stack Configuration

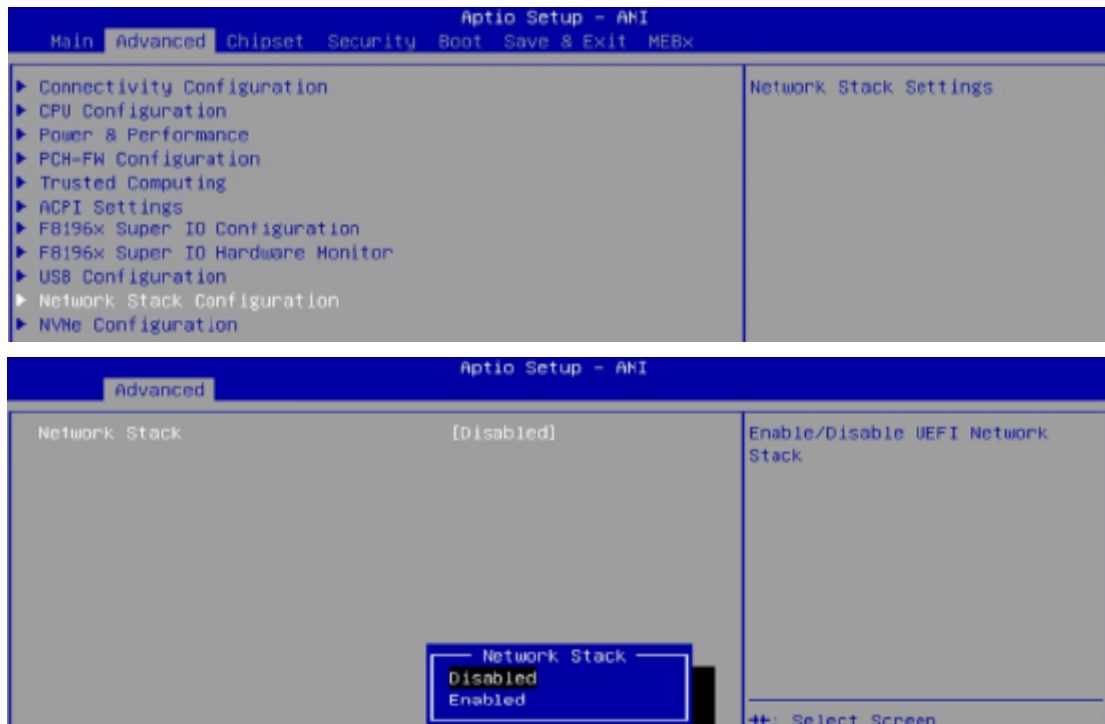

BIOS Setting	Description
Network Stack	Enable / Disable UEFI Network Stack. Options: Disabled / Enabled

4.4.11 NVME Configuration

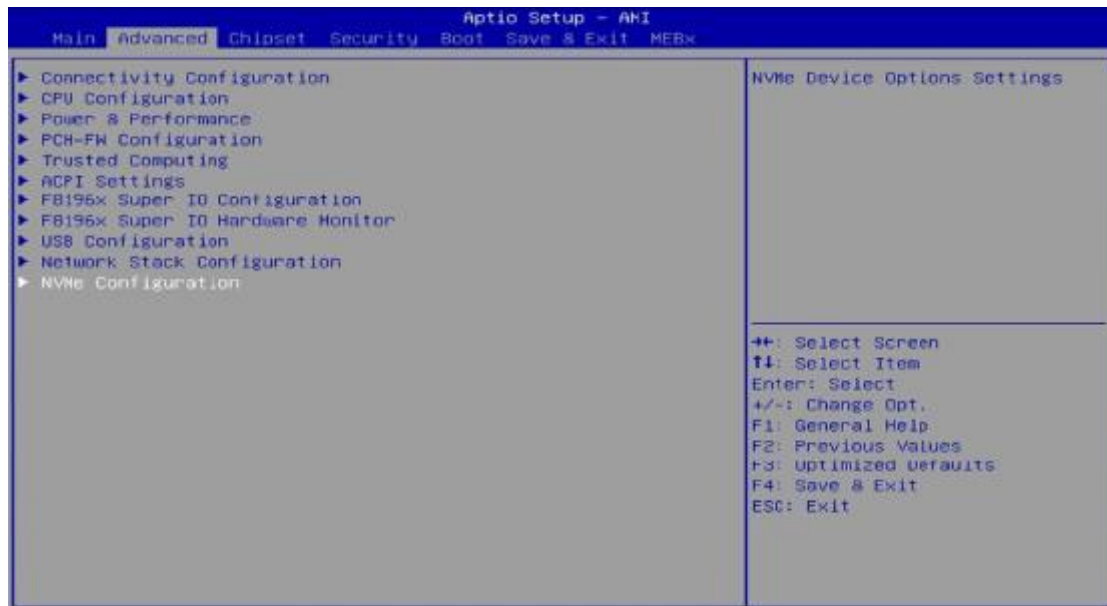

4.5 Chipset Settings

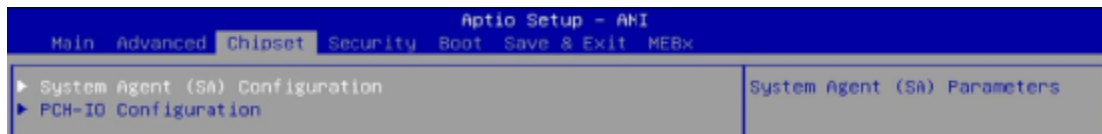

BIOS Setting	Description
System Agent (SA) Configuration	System Agent (SA) parameters
PCH-IO Configuration	PCH parameters

4.5.1 System Agent (SA) Configuration

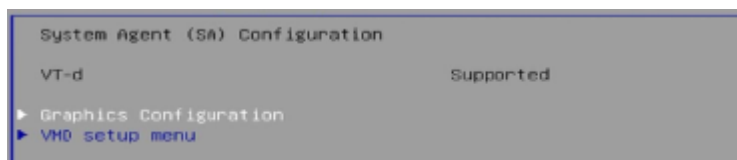

BIOS Setting	Description
VT-d	Checks if VT-d function on MCH is supported.
Graphics Configuration	Configures the graphics settings.
VMD Configuration	Enable/Disable VMD controller.

4.5.1.1. Graphics Configuration

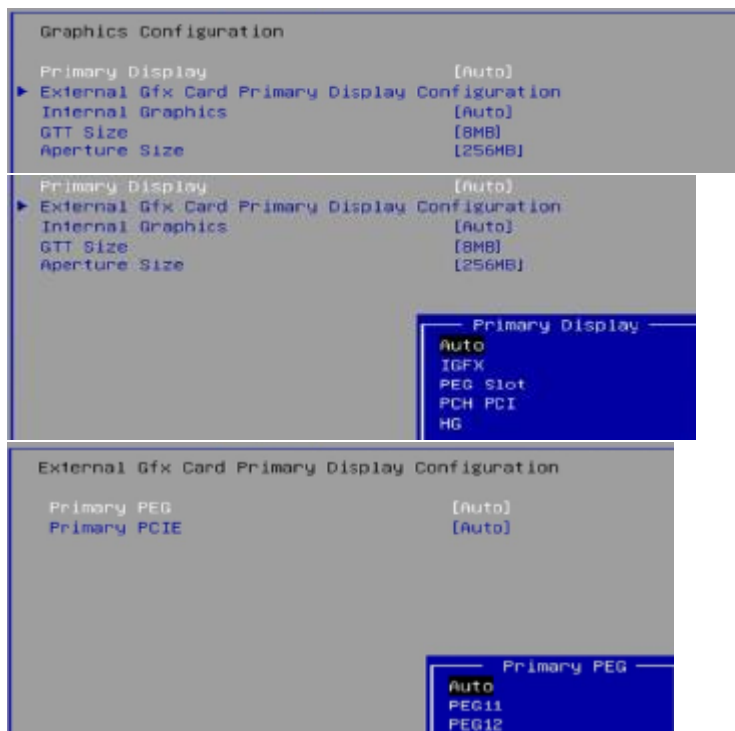

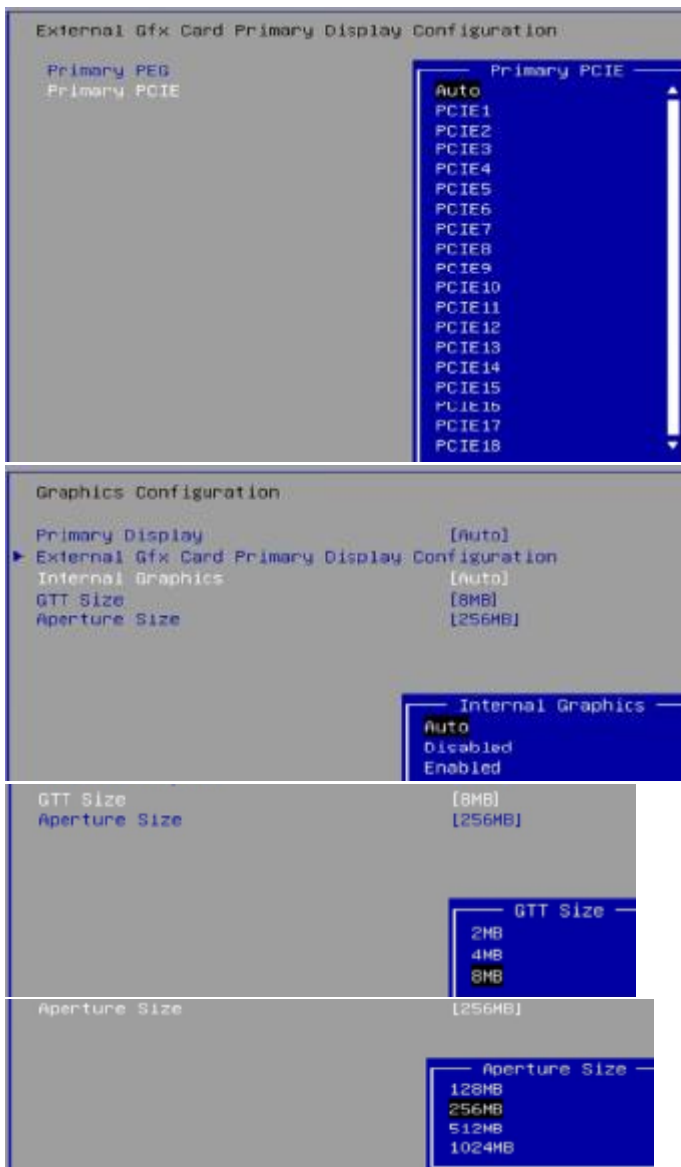

BIOS Setting	Description
Primary Display	Selects which of PEG0/PEG1/PEG2/PEG3 graphics device which should be primary PEG.
External Gfx card primary display configuration	Selects which of IGFX/PEG/PCI device to be primary display or select HG for Hybrid Gfx.
Internal Graphics	Keep IGFX enabled based on the setup options.
GTT Size	Sets the GTT size as 2 MB, 4 MB, or 8 MB.
Aperture Size	Select the aperture size. Note: Above 4 GB MMIO BIOS assignment is automatically enabled when selecting 2048 MB aperture. To use this feature, disable CSM support.

4.5.2 PCH-IO Configuration

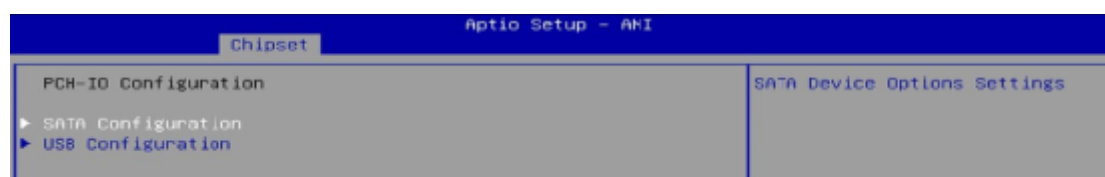

BIOS Setting	Description
SATA Configuration	Configures SATA devices.
USB Configuration	USB configuration settings.

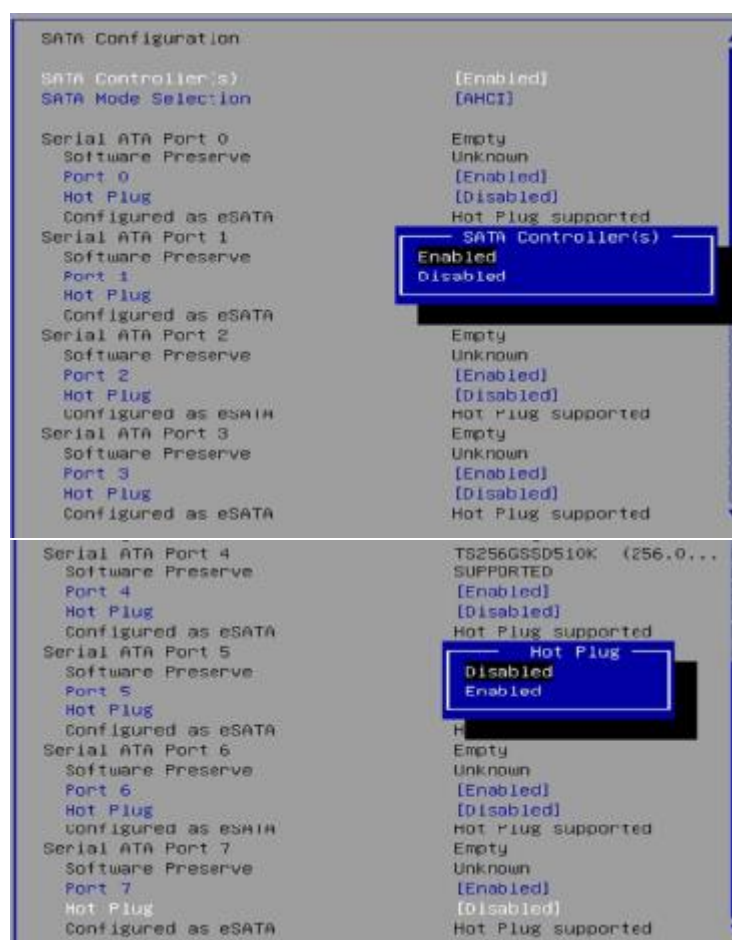

PCH-IO Configuration	
▶ SATA Configuration	
▶ USB Configuration	
USB Configuration	
M.2 B-Key USB2.0 Control	[Enabled]
Enable/Disable this USB Physical Connector (physical port). Once disabled, any USB devices plug into the connector will not be detected by BIOS or OS.	

4.6 Security Settings

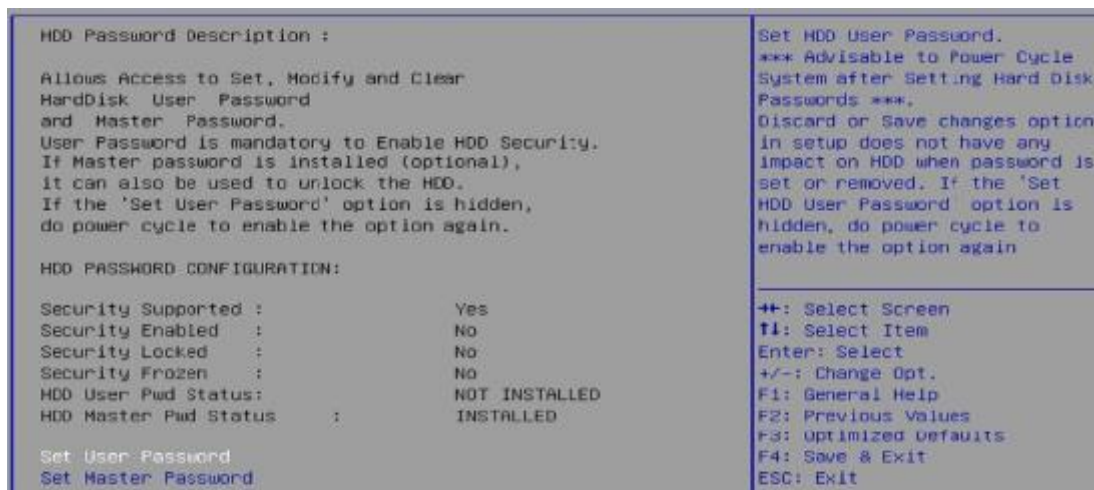
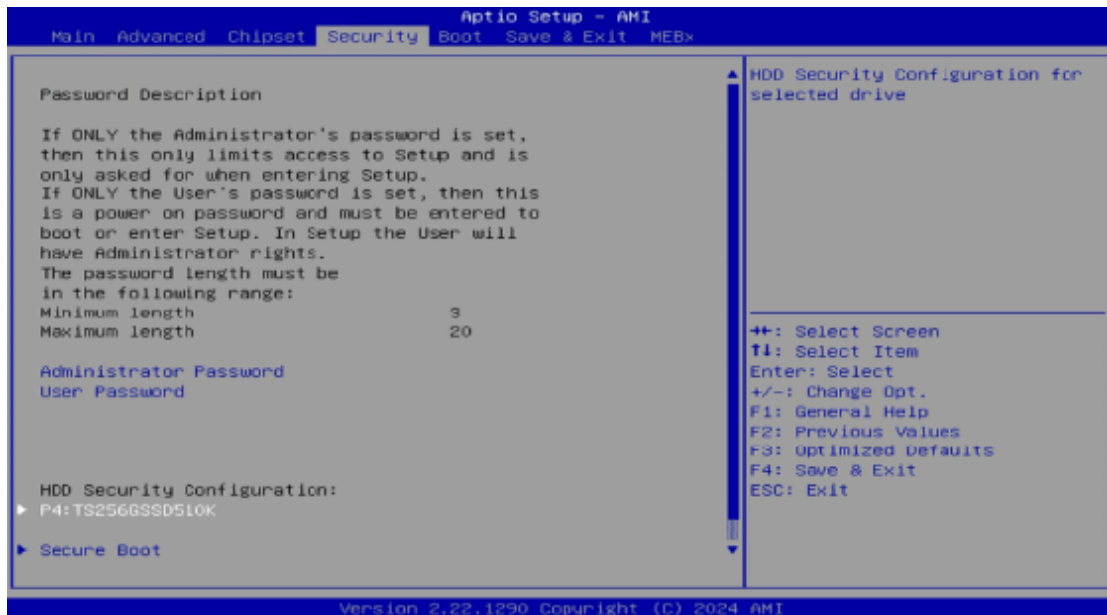

BIOS Setting	Description
Administrator Password	Sets an administrator password for the setup utility.
User Password	Sets a user password.
Secure Boot	Secure Boot feature is Active if Secure Boot is Enabled. Platform Key(PK) is enrolled and the System is in User mode. The mode change requires platform reset.
Secure Boot Mode	Secure Boot mode options: Standard or Custom. In Custom mode, Secure Boot Policy variables can be configured by a physically present user without full authentication.

System Mode	Setup	Secure Boot feature is Active if Secure Boot is Enabled, Platform Key(PK) is enrolled and the System is in User mode. The mode change requires platform reset.	
Secure Boot	[Disabled] Not Active		
Secure Boot Mode	[Custom]		
System Mode	Setup	Secure Boot mode options: Standard or Custom. In Custom mode, Secure Boot Policy variables can be configured by a physically present user without full authentication.	
Secure Boot	[Disabled] Not Active		
Secure Boot Mode	[Custom]		
▶ Restore Factory Keys			
System Mode	Setup	Force System to User Mode. Install factory default Secure Boot key databases.	
Secure Boot	[Disabled] Not Active		
Secure Boot Mode	[Custom]		
▶ Restore Factory Keys			
Vendor Keys	Valid	Install factory default Secure Boot keys after the platform reset and while the System is in Setup mode.	
Factory Key Provision	[Disabled]		
▶ Restore Factory Keys			
▶ Reset To Setup Mode			
▶ Enroll Efi Image			
▶ Export Secure Boot variables			
Secure Boot variable	Size	Keys	Key Source
▶ Platform Key (PK)	0	0	No Keys
▶ Key Exchange Keys (KEK)	0	0	No Keys
▶ Authorized Signatures (db)	0	0	No Keys
▶ Forbidden Signatures(dbx)	0	0	No Keys
▶ Authorized TimeStamps(dbt)	0	0	No Keys
▶ OsRecovery Signatures(dbr)	0	0	No Keys
			++: Select Screen Ti: Select Item Enter: Select

BIOS Setting	Description
Factory Key Provision	Install factory default Secure Boot keys after the platform reset and while the System is in Setup mode
Restore Factory Keys	Force System to User Mode. Install factory default Secure Boot key databases
Export Secure Boot variables	Copy NVRAM content of Secure Boot variables to files in a root folder on a file system device
Enroll Efi Image	Allow the image to run in Secure Boot mode. Enroll SHA256 Hash certificate of a PE image into Authorized Signature Database (db)
Platform Key(PK)	Enroll Factory Defaults or load certificates from a file: 1. Public Key Certificate: a) EFI_SIGNATURE_LIST b) EFI_CERT_X509 (DER) c) EFI_CERT_RSA2048 (bin) D) EFI_CERT_shaxxx 2. Authenticated UEFI Variable 3. EFI PE/COFF Image (SHA256) Key Source: Factory, External, Mixed

4.7 Boot Settings

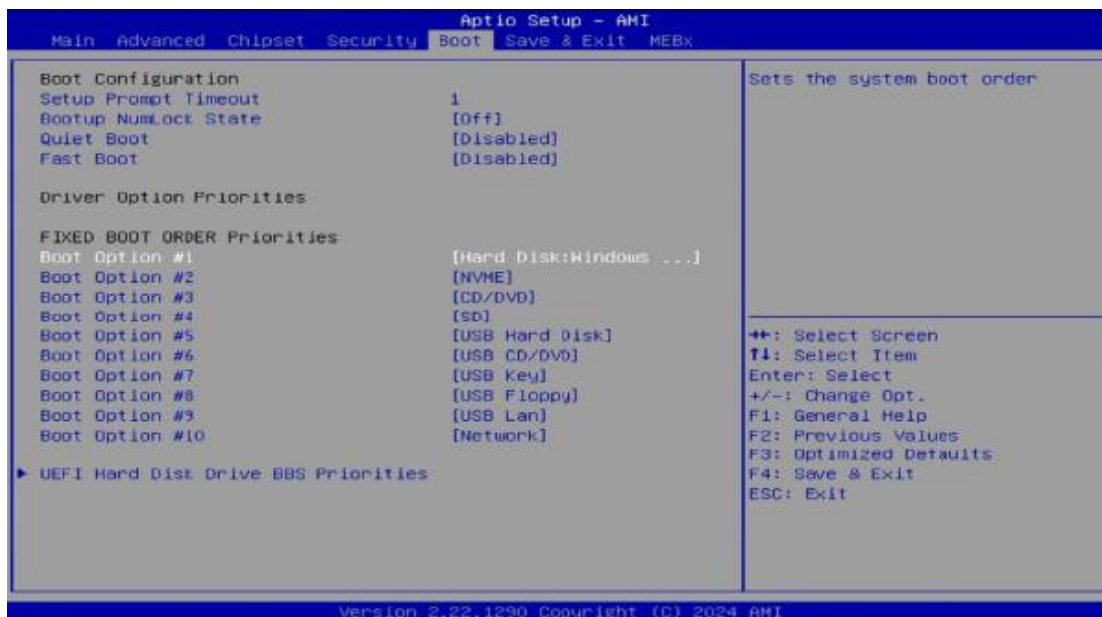

BIOS Setting	Description
Setup Prompt Timeout	Number of seconds to wait for setup activation key. 65535 (0xFFFF) means indefinite waiting.
Bootup NumLock State	Selects the keyboard NumLock state.
Quiet Boot	Enables / Disables Quiet Boot option.
Fast Boot	Enables / Disables boot with initialization of a minimal set of devices required to launch the active boot option. Has no effect for BBS boot options.
Boot mode select	Selects a Boot mode, Legacy / UEFI.
Fixed Boot Order Priorities	Sets the system boot order.
UEFI Hard Disk Drive BBS Priorities	Specifies the Boot Device Priority sequence from available UEFI Hard Disk Drives

4.8 Save & Exit Settings

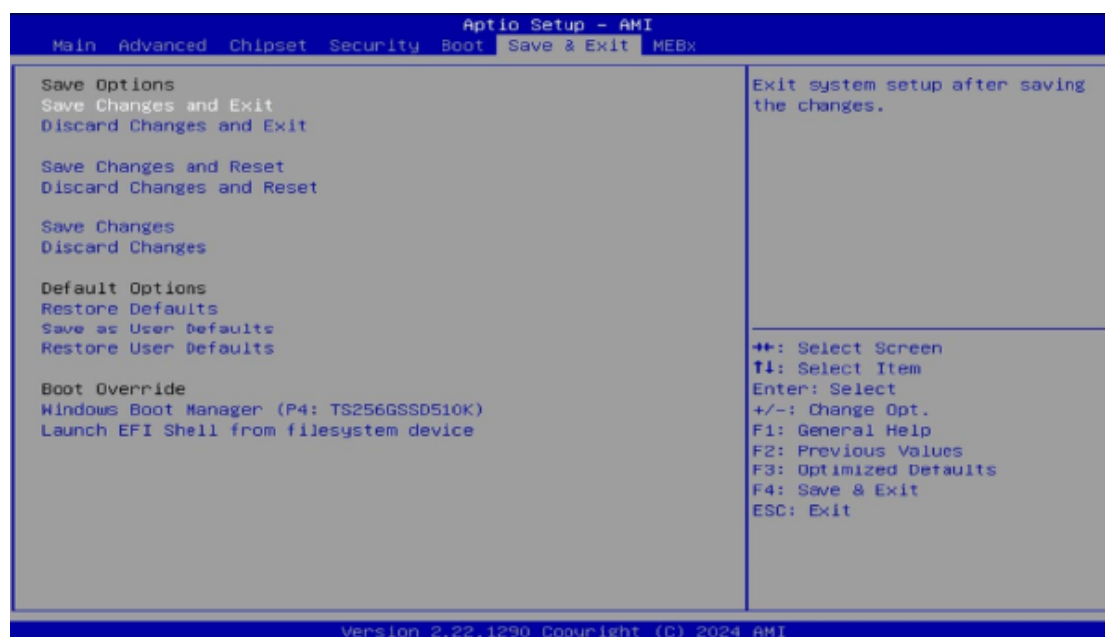

BIOS Setting	Description
Save Changes and Exit	Exits system setup after saving the changes.
Discard Changes and Exit	Exits system setup without saving any changes.
Save Changes and Reset	Resets the system after saving the changes.
Discard Changes and Reset	Resets system setup without saving any changes.
Save Changes	Saves changes done so far to any of the setup options.
Discard Changes	Discards changes done so far to any of the setup options.
Restore Defaults	Restores / Loads defaults values for all the setup options.
Save as User Defaults	Saves the changes done so far as user defaults.
Restore User Defaults	Restores the user defaults to all the setup options.

4.9 MEBx



Appendix

This section provides the mapping addresses of peripheral devices and the sample code of watchdog timer configuration.

- I/O Port Address Map
- Interrupt Request Lines (IRQ)
- Watchdog Timer Configuration

A. I/O Port Address Map

Each peripheral device in the system is assigned a set of I/O port addresses which also becomes the identity of the device. The following table lists the I/O port addresses used.

Resource	Device
0x00000A00-0x00000A0F	Motherboard resources
0x00000A10-0x00000A1F	Motherboard resources
0x00000A20-0x00000A2F	Motherboard resources
0x0000002E-0x0000002F	Motherboard resources
0x0000004E-0x0000004F	Motherboard resources
0x00000061-0x00000061	Motherboard resources
0x00000063-0x00000063	Motherboard resources
0x00000065-0x00000065	Motherboard resources
0x00000067-0x00000067	Motherboard resources
0x00000070-0x00000070	Motherboard resources
0x00000080-0x00000080	Motherboard resources
0x00000092-0x00000092	Motherboard resources
0x000000B2-0x000000B3	Motherboard resources
0x00000680-0x0000069F	Motherboard resources
0x0000164E-0x0000164F	Motherboard resources
0x00000040-0x00000043	System timer
0x00000050-0x00000053	System timer
0x00004000-0x00004FFF	PCI Express Root Port
0x00004000-0x00004FFF	NVIDIA RTX A2000
0x000003F8-0x000003FF	Communications Port (COM1)
0x000002F8-0x000002FF	Communications Port (COM2)
0x000003E8-0x000003EF	Communications Port (COM3)
0x000002E8-0x000002EF	Communications Port (COM4)
0x000003E0-0x000003E7	Communications Port (COM5)
0x000002E0-0x000002E7	Communications Port (COM6)
0x00000020-0x00000021	Programmable interrupt controller
0x00000024-0x00000025	Programmable interrupt controller
0x00000028-0x00000029	Programmable interrupt controller
0x0000002C-0x0000002D	Programmable interrupt controller
0x00000030-0x00000031	Programmable interrupt controller
0x00000034-0x00000035	Programmable interrupt controller

0x00000038-0x00000039	Programmable interrupt controller
0x0000003C-0x0000003D	Programmable interrupt controller
0x000000A0-0x000000A1	Programmable interrupt controller
0x000000A4-0x000000A5	Programmable interrupt controller
0x000000A8-0x000000A9	Programmable interrupt controller
0x000000AC-0x000000AD	Programmable interrupt controller
0x000000B0-0x000000B1	Programmable interrupt controller
0x000000B4-0x000000B5	Programmable interrupt controller
0x000000B8-0x000000B9	Programmable interrupt controller
0x000000BC-0x000000BD	Programmable interrupt controller
0x000004D0-0x000004D1	Programmable interrupt controller
0x00002000-0x000020FE	Motherboard resources
0x00000060-0x00000060	Standard PS/2 Keyboard
0x00000064-0x00000064	Standard PS/2 Keyboard
0x00001854-0x00001857	Motherboard resources

B. Interrupt Request Lines (IRQ)

Peripheral devices use interrupt request lines to notify CPU for the service required. The following table shows the IRQ used by the devices on board.

Resource	Device
IRQ 4294967281~86	Intel(R) I210 Gigabit Network Connection #3
IRQ 4294967287	Intel(R) USB 3.20 eXtensible Host Controller - 1.20 (Microsoft)
IRQ 32	Intel(R) Serial IO I2C Host Controller - 7AFD
IRQ 0	System timer
IRQ 43	Intel(R) Serial IO I2C Host Controller - 7ACF
IRQ 4294967270	Intel(R) Management Engine Interface #1
IRQ 4294967291	PCI Express Root Port
IRQ 4	Communications Port (COM1)
IRQ 3	Communications Port (COM2)
IRQ 5	Communications Port (COM3)
IRQ 7	Communications Port (COM4)
IRQ 10	Communications Port (COM5)
IRQ 11	Communications Port (COM6)
IRQ 4294967289	Standard SATA AHCI Controller
IRQ 19	Intel(R) Active Management Technology - SOL (COM7)
IRQ 4294967293	PCI Express Root Port
IRQ 31	Intel(R) Serial IO I2C Host Controller - 7AFC
IRQ 16	Intel(R) Serial IO UART Host Controller - 7AA8
IRQ 4294967271~75	Intel(R) Ethernet Controller I226-V #2
IRQ 29	Intel(R) Serial IO I2C Host Controller - 7ACE
IRQ 4294967290/92	PCI Express Root Port
IRQ 55~ IRQ 511	Microsoft ACPI-Compliant System
IRQ 17	High Definition Audio Controller
IRQ 17	High Definition Audio Controller
IRQ 4294967276~80	Intel(R) Ethernet Controller I226-LM #2
IRQ 37	Intel(R) Serial IO SPI Host Controller - 7AAB
IRQ 1	Standard PS/2 Keyboard
IRQ 12	Microsoft PS/2 Mouse
IRQ 14	Intel(R) Serial IO GPIO Host Controller - INTC1056
IRQ 4294967288	NVIDIA RTX A2000

C. Watchdog Timer Configuration

The Watchdog Timer (WDT) is used to generate a variety of output signals after a user programmable count. The WDT is suitable for the use in the prevention of system lock-up, such as when software becomes trapped in a deadlock. Under these sorts of circumstances, the timer will count to zero and the selected outputs will be driven.

Under normal circumstance, you will need to restart the WDT at regular intervals before the timer counts to zero.

Sample Code

```
//-----  
//  
// THIS CODE AND INFORMATION IS PROVIDED "AS IS" WITHOUT WARRANTY OF ANY  
// KIND, EITHER EXPRESSED OR IMPLIED, INCLUDING BUT NOT LIMITED TO THE  
// IMPLIED WARRANTIES OF MERCHANTABILITY AND/OR FITNESS FOR A  
// PARTICULAR PURPOSE.  
//  
//-----  
#include <dos.h>  
#include <conio.h>  
#include <stdio.h>  
#include <stdlib.h>  
#include "F81966.H"  
//-----  
int main (int argc, char *argv[]);  
void EnableWDT(int);  
void DisableWDT(void);  
//-----  
int main (int argc, char *argv[])  
{  
    unsigned char bBuf;  
    unsigned char bTime;  
    char **endptr;  
  
    char SIO;  
  
    printf("Fintek 81966 watch dog program\n");  
    SIO = Init_F81966();  
    if (SIO == 0)  
    {  
        printf("Can not detect Fintek 81966, program abort.\n");  
        return(1);  
    }  
    //if (SIO == 0)  
  
    if (argc != 2)  
    {  
        printf(" Parameter incorrect!!\n");  
        return (1);  
    }  
  
    bTime = strtol (argv[1], endptr, 10);
```

```

printf("System will reset after %d seconds\n", bTime);

if (bTime)
{ EnableWDT(bTime); }
else
{ DisableWDT(); }
return 0;
}
//-----
void EnableWDT(int interval)
{
    unsigned char bBuf;

    bBuf = Get_F81966_Reg(0x2B);
    bBuf &= (~0x20);
    Set_F81966_Reg(0x2B, bBuf); //Enable WDTO

    Set_F81966_LD(0x07); //switch to logic device 7
    Set_F81966_Reg(0x30, 0x01); //enable timer

    bBuf = Get_F81966_Reg(0xF5);
    bBuf &= (~0x0F);
    bBuf |= 0x52;
    Set_F81966_Reg(0xF5, bBuf); //count mode is second

    Set_F81966_Reg(0xF6, interval); //set timer

    bBuf = Get_F81966_Reg(0xFA);
    bBuf |= 0x01;
    Set_F81966_Reg(0xFA, bBuf); //enable WDTO output

    bBuf = Get_F81966_Reg(0xF5);
    bBuf |= 0x20;
    Set_F81966_Reg(0xF5, bBuf); //start counting
}
//-----
void DisableWDT(void)
{
    unsigned char bBuf;

    Set_F81966_LD(0x07); //switch to logic device 7

    bBuf = Get_F81966_Reg(0xFA);
    bBuf &= ~0x01;
    Set_F81966_Reg(0xFA, bBuf); //disable WDTO output

    bBuf = Get_F81966_Reg(0xF5);
    bBuf &= ~0x20;
    bBuf |= 0x40;
    Set_F81966_Reg(0xF5, bBuf); //disable WDT
}
//-----

```

```

//-----
//
// THIS CODE AND INFORMATION IS PROVIDED "AS IS" WITHOUT WARRANTY OF ANY
// KIND, EITHER EXPRESSED OR IMPLIED, INCLUDING BUT NOT LIMITED TO THE
// IMPLIED WARRANTIES OF MERCHANTABILITY AND/OR FITNESS FOR A
// PARTICULAR PURPOSE.
//
//-----
#include "F81966.H"
#include <dos.h>
//-----
unsigned int F81966_BASE;
void Unlock_F81966 (void);
void Lock_F81966 (void);
//-----
unsigned int Init_F81966(void)
{
    unsigned int result;
    unsigned char ucDid;

    F81966_BASE = 0x4E;
    result = F81966_BASE;

    ucDid = Get_F81966_Reg(0x20);
    if (ucDid == 0x07) //Fintek 81966
    { goto Init_Finish; }

    F81966_BASE = 0x2E;
    result = F81966_BASE;

    ucDid = Get_F81966_Reg(0x20);
    if (ucDid == 0x07) //Fintek 81966
    { goto Init_Finish; }

    F81966_BASE = 0x00;
    result = F81966_BASE;

Init_Finish:
    return (result);
}
//-----
void Unlock_F81966 (void)
{
    outportb(F81966_INDEX_PORT, F81966_UNLOCK);
    outportb(F81966_INDEX_PORT, F81966_UNLOCK);
}
//-----
void Lock_F81966 (void)
{
    outportb(F81966_INDEX_PORT, F81966_LOCK);
}
//-----
void Set_F81966_LD( unsigned char LD)
{

```

```

        Unlock_F81966();
        outportb(F81966_INDEX_PORT, F81966_REG_LD);
        outportb(F81966_DATA_PORT, LD);
        Lock_F81966();
    }
    //-----
void Set_F81966_Reg( unsigned char REG, unsigned char DATA)
{
    Unlock_F81966();
    outportb(F81966_INDEX_PORT, REG);
    outportb(F81966_DATA_PORT, DATA);
    Lock_F81966();
}
//-----
unsigned char Get_F81966_Reg(unsigned char REG)
{
    unsigned char Result;
    Unlock_F81966();
    outportb(F81966_INDEX_PORT, REG);
    Result = inportb(F81966_DATA_PORT);
    Lock_F81966();
    return Result;
}
//-----

//-----
//
// THIS CODE AND INFORMATION IS PROVIDED "AS IS" WITHOUT WARRANTY OF ANY
// KIND, EITHER EXPRESSED OR IMPLIED, INCLUDING BUT NOT LIMITED TO THE
// IMPLIED WARRANTIES OF MERCHANTABILITY AND/OR FITNESS FOR A
// PARTICULAR PURPOSE.
//
//-----
#ifndef F81966_H
#define F81966_H      1
//-----
#define F81966_INDEX_PORT (F81966_BASE)
#define F81966_DATA_PORT (F81966_BASE+1)
//-----
#define F81966_REG_LD  0x07
//-----
#define F81966_UNLOCK  0x87
#define F81966_LOCK  0xAA
//-----
unsigned int Init_F81966(void);
void Set_F81966_LD( unsigned char);
void Set_F81966_Reg( unsigned char,
unsigned char); unsigned char
Get_F81966_Reg( unsigned char);
//-----
#endif // F81966_H

```