

MB8100

Intel® Atom® 945GSE
Mini-ITX Motherboard

USER'S MANUAL

Version 1.1A

Acknowledgments

Award is a registered trademark of Award Software International, Inc.
PS/2 is a trademark of International Business Machines Corporation.
Intel and Atom are registered trademarks of Intel Corporation.
Microsoft Windows is a registered trademark of Microsoft Corporation.
Winbond is a registered trademark of Winbond Electronics Corporation.
All other product names or trademarks are properties of their respective owners.

Table of Contents

Introduction	1
Product Description.....	1
Checklist.....	2
MB8100 Specifications.....	3
Board Dimensions	4
Installations	6
Installing the Memory	7
Setting the Jumpers	8
Connectors on MB8100	12
BIOS Setup	23
Drivers Installation	47
Intel Chipset Software Installation Utility	48
VGA Drivers Installation	49
Realtek High Definition Audio Driver Installation.....	50
LAN Drivers Installation.....	51
Appendix.....	52
A. I/O Port Address Map	52
B. Interrupt Request Lines (IRQ).....	53
C. Watchdog Timer Configuration	54

This page is intentionally left blank.

Introduction

Product Description

The MB8100 Mini ITX board incorporates the Intel® 945GSE Express Chipset with ICH7M, configured with the Intel Atom processor N270 at 1.6GHz, FSB533 and the Mobile Intel 945GSE Express Chipset with the ICH7M.

The MB8100 Mini ITX board features the Intel's Graphics Media Accelerator 950 core, making it compatible with Windows Vista Premium, and Chrontel CH7308 LVDS controller to support display interfaces including VGA CRT and 18/24-bit dual channel LVDS.

The new Intel® Graphics Media Accelerator 950 (Intel® GMA 950) graphics core is an intelligent and responsive graphics engine built into the chipset that is on the motherboard. This integration provides incredible visual quality, faster graphics performance and flexible display options without the need for a separate graphics card.

The main features of the MB8100 Mini ITX Motherboard are:

- Supports Intel Atom 270 processor with 1.6GHz speed
- Two DDRII SDRAM DIMM supports up to 2GB of DDR2 400/533MHz memory
- Onboard 10/100/1000 Realtek RTL8111C PCI-Express Gigabit LAN
- Intel® 945GSE/Chrontel 7308 VGA for CRT, dual channel LVDS
- 2x SATA, 8x USB 2.0, 4x COM, Watchdog timer
- 1x PCI, 1x MiniPCIe, CF socket, DC-in for +12V input

Dimensions of the board are 170mm x 170mm.

Ordering Information:

MB8100F: Intel Atom, 1.6GHz, 945GSE chipset with LVDS, 2x Gigabit LAN, Mini PCI-E, PCI

MB8100: Intel Atom, 1.6GHz, 945GSE chipset with LVDS, 1x Gigabit LAN, Mini PCI-E, PCI

Checklist

Your MB8100 package should include the items listed below.

- The MB8100 Intel® Atom Mini-ITX motherboard
- This User's Manual (Electronic version or Printed)
- 1 CD containing support drivers and tools.
- Cable kit:
 - IDE
 - 2x Serial port
 - Serial ATA
 - Parallel port

CAUTION:

RISK OF EXPLOSION; IF BATTERY IS REPLACED BY AN INCORRECT TYPE. DISPOSE OF USED BATTERIES ACCORDING TO THE INSTRUCTIONS PROPOSED BY YOU LOCAL AUTHORITY.

MB8100 Specifications

CPU Type	Intel® Atom™ N270 processor (45nm)
CPU FSB	CPU Clock speed = 1.60GHz FSB=533MHz L2 Cache=512K TDP=2.5W
Green /APM	APM1.2
BIOS	Award BIOS, support ACPI function
Chipset	Intel 945GSE Chipset GMCH: 82945GSE 27mm x 27mm -998-pin FCBGA ICH7M: 82801GBM 31mm x 31mm -652-pin BGA
Memory	DDRII 533 DIMM x1. Max. 2GB Supports Single channel, without ECC function
VGA	945GSE built-in, Intel® Graphics Media Accelerator 950 Graphics Core, Supports CRT
LVDS	Chrontel 7308B for 18/24-bit dual channel LVDS interface
LAN	Realtek RTL8111C PCI-Express Gigabit LAN controller x2
USB	ICH7M built-in USB 2.0 host controller, support 8 ports
Serial ATA Ports	ICH7M built-in SATA controller, supports 2 ports
Parallel IDE	ICH7M built-in one channel Ultra DMA 33/66/100, CF
Audio	ICH7M built -in audio controller w/ ALC 655 AC97 audio codec 5.1-channel (Line-out & Microphone)
LPC I/O	Winbond W83627EHG: COM1 (RS232), COM2 (RS232/422/485), LPT port; Hardware monitor (3 thermal inputs, 4 voltage monitor inputs, VIDO-4 & 2 fan headers)
2'nd LPC I/O	Fintek F81216DG COM3 & COM4(RS232)
Digital IO	4 in & 4 out
Keyboard/Mouse	Supports PS/2 Keyboard/Mouse connectors
Expansion Slots	PCI slot x1, PCI-E (x1) slot x1 and Mini PCI-E (x1) socket x1
Power Connector	DC power jack x1 for +12V DC-in
Edge Connectors	PS/2 connector x1 for keyboard/mouse Gigabit LAN RJ-45 + dual USB stack connector 10/100 LAN RJ45 + dual USB stack connector Dual USB stack connector for USB5/USB6 DB15 connector for VGA output 3x1 stack mini jacks (0.125") for HD audio (Line-in, Line-Out, Microphone); DC-in jack
Onboard Header/Connectors	DF13 connector x2 for LVDS SATA connector x2 for 2 SATA ports 40-pin box-header x1 for IDE1 CF Connector x1 @ solder side 8-pin header x1 for USB 7,8 20-pin header x1 for LPT port 20-pin DF11 connector x2 for COM1/COM2, COM3/COM4 (Powered with 5V or 12V or as ring-in) 10-pin header x1 for audio Line-Out & Microphone 10 pin-headerx1 for Digital I/O
Watchdog Timer	Yes (256 segments, 0, 1, 2...255 sec/min)
Other	Modem Wakeup, LAN Wakeup
RoHS	Yes
Board Size	170mm x 170mm (Mini ITX form factor)

Board Dimensions

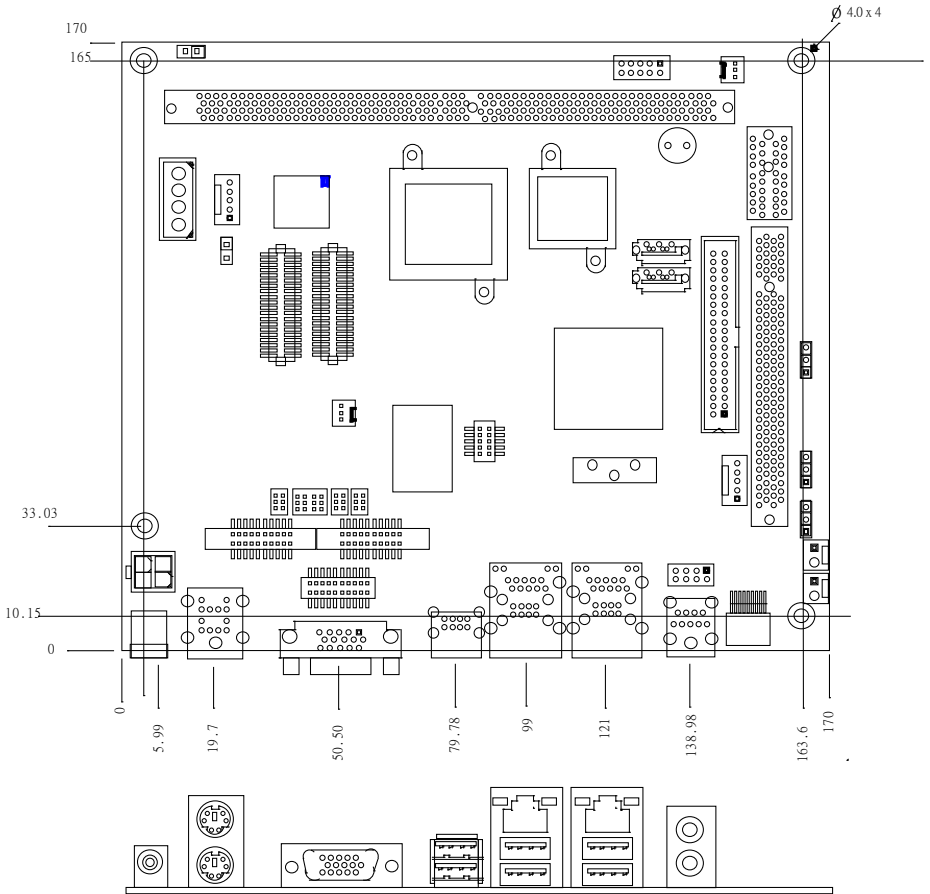

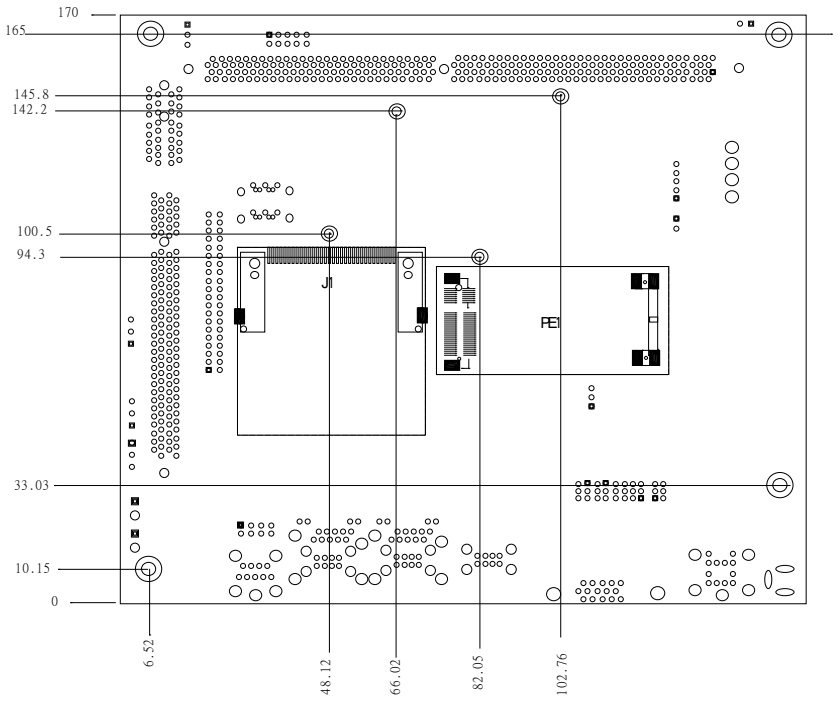

Installations

This section provides information on how to use the jumpers and connectors on the MB8100 in order to set up a workable system. The topics covered are:

Installing the Memory	7
Setting the Jumpers	8
Connectors on MB8100	12

CAUTION:

RISK OF EXPLOSION; IF BATTERY IS REPLACED BY AN INCORRECT TYPE. DISPOSE OF USED BATTERIES ACCORDING TO THE INSTRUCTIONS PROPOSED BY YOU LOCAL AUTHORITY.

Also take note of the following:

The connector PW1 is output only, do not connect power to this output it will damage the board.

Installing the Memory

The MB8100 board supports two DDR2 memory socket for a maximum total memory of 2GB in DDR2 memory type.

Installing and Removing Memory Modules

To install the DDR2 modules, locate the memory slot on the board and perform the following steps:

1. Hold the DDR2 module so that the key of the DDR2 module align with those on the memory slot.
2. Gently push the DDR2 module in an upright position until the clips of the slot close to hold the DDR2 module in place when the DDR2 module touches the bottom of the slot.
3. To remove the DDR2 module, press the clips with both hands.

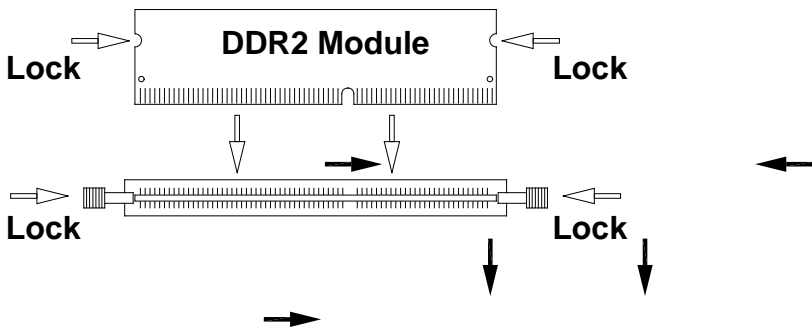



Setting the Jumpers

Jumpers are used on MB8100 to select various settings and features according to your needs and applications. Contact your supplier if you have doubts about the best configuration for your needs. The following lists the connectors on MB8100 and their respective functions.

Jumper Locations on MB8100	9
JP3: ATX/AT Mode Select	10
JP4, JP5: RS232/422/485 (COM2) Selection	10
JP15: COM4 RS232 +5V / +12V Power Setting	10
JP14: COM3 RS232 +5V / +12V Power Setting	10
JP1: Clear CMOS Setting	11
JP2: CompactFlash Slave/Master Selection	11

JP3: ATX/AT Mode Select

JP3	ATX / AT
 Open	ATX mode
 Short	AT mode

JP4, JP5: RS232/422/485 (COM2) Selection

COM1/3/4 is fixed for RS-232 use only.

COM2 is selectable for RS232, RS-422 and RS-485.

The following table describes the jumper settings for COM2 selection.

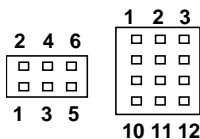

Jumper	RS232	RS422	RS485
JP4 2X3	1-2	3-4	5-6
JP5 3X4	1-2 4-5 7-8 10-11	2-3 5-6 8-9 11-12	2-3 5-6 8-9 11-12

JP15: COM4 RS232 +5V / +12V Power Setting

Pin #	Signal Name	JP15	Signal Name	Pin #
1	RI		+12V	2
3	RI (Default)		RI (Default)	4
5	RI		+5V	6

COM4 Settings: Pin 1-2 short = +12V, Pin 5-6 short = +5V, Pin 3-4 Standard COM Port

JP14: COM3 RS232 +5V / +12V Power Setting

Pin #	Signal Name	JP14	Signal Name	Pin #
1	RI		+12V	2
3	RI (Default)		RI (Default)	4
5	RI		+5V	6

COM3 Settings: Pin 1-2 short = +12V, Pin 5-6 short = +5V, Pin 3-4 Standard COM Port

JP1: Clear CMOS Setting

JP1	Setting
	Clear CMOS
	Normal

JP2: Compact Flash Slave/Master Selection

JP2	CF Setting
	Master
	Slave

Connectors on MB8100

The connector on MB8100 allows you to connect external devices such as keyboard, floppy disk drives, hard disk drives, printers, etc. The following table lists the connectors on MB8100 and their respective functions.

Connector Locations on MB8100	13
FAN1: CPU Fan Power Connector	15
FAN2: System Fan Power Connector	15
CON9: DC Jack (DC in, 12V)	15
PSKBM1: PS/2 Keyboard and PS/2 Mouse Connectors.....	15
VGA: VGA Connector.....	16
USB1: USB1/2 Ports	16
USBLAN1: 10/100/1000 RJ-45 and USB5/6 Ports	16
USBLAN2: 10/100/1000 RJ-45 and USB7/8 Ports	16
AUDIO1: Audio Connector	16
SATA1,SATA2 : Serial ATA Connectors	16
PE1: Mini PCI- E(x1) Connector (bottom side).....	16
J1: Compact Flash Connector (bottom side)	16
PCI1: PCI Slot (supports 2 Master)	16
PCIE1: PCIE x1 Slot.....	16
IDE1: IDE Connector	17
CON10 : LCD Backlight Connector	17
PWR1: HDD Power Connector (Output: Max. 2A).....	17
ATX12V1: ATX_12V Connector.....	18
PANEL1: Power LED Connector	18
CON6: Digital I/O.....	18
CON5: COM1, COM2 Serial Ports	18
LVDS2,LVDS4: LVDS Connectors (1st channel, 2nd channel).....	19
PANEL1: System Function Connector	19
CON3: COM3, COM4 Serial Ports	20
J4: USB3/4 Port Pin Header	21
J2,J3: Audio Front Header	21
CON11: Smart Battery Connector	21
LPT1: Parallel Port	21

Connector Locations on MB8100

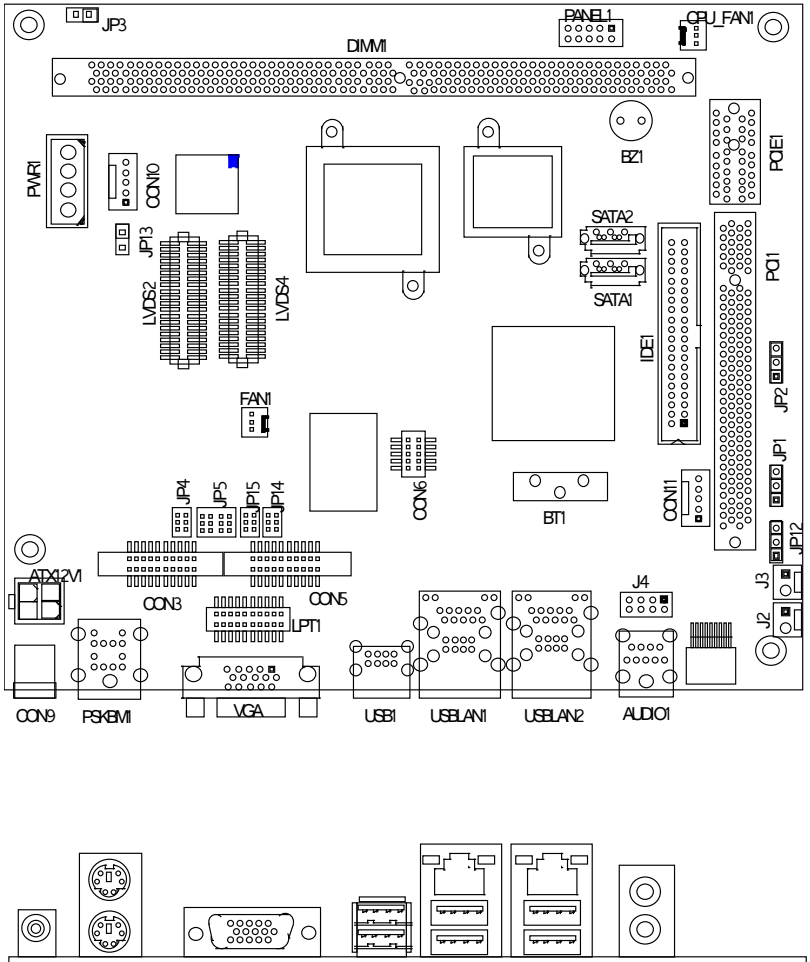

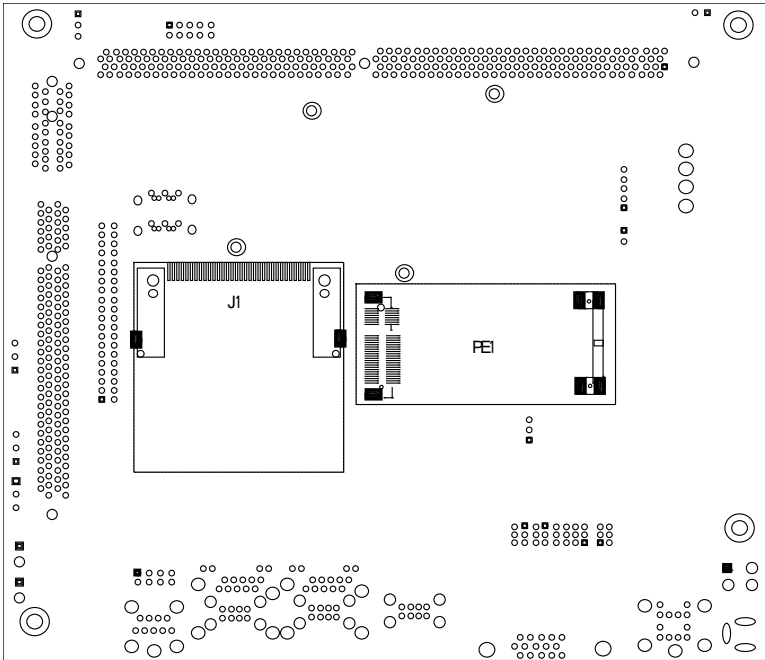

CPU_FAN1: CPU Fan Power Connector

FAN1 is a 3-pin header for the CPU fan. The fan must be 12V (Max. 500mA).



Pin #	Signal Name
1	Ground
2	+12V
3	Rotation detection

FAN1: System Fan Power Connector

FAN1 is a 3-pin header for system fans. The fan must be 12V (Max. 500mA).



Pin #	Signal Name
1	Ground
2	+12V
3	Rotation detection

PSKBM1: PS/2 Keyboard and PS/2 Mouse Connectors

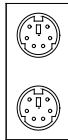

PS/2 Mouse

PS/2 Keyboard

Signal Name	Keyboard	Mouse	Signal Name
Keyboard data	1	1	Mouse data
N.C.	2	2	N.C.
GND	3	3	GND
5V	4	4	5V
Keyboard clock	5	5	Mouse clock
N.C.	6	6	N.C.

Edge connectors (MB8100F)

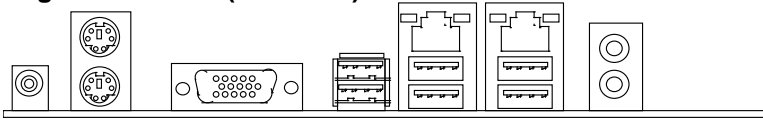

Edge Connectors (MB8100)

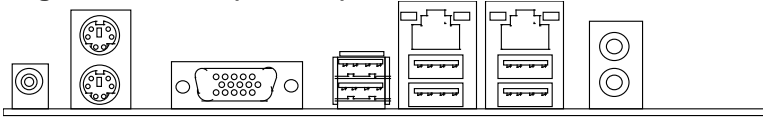

CON9: DC Jack (DC in, 12V)

Remarks: CON9 and ATX12V1 cannot be connected at the same time.

VGA: VGA Connector

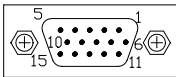

Signal Name	Pin #	Pin #	Signal Name
Red	1	2	Green
Blue	3	4	N.C.
GND	5	6	GND
GND	7	8	GND
VCC	9	10	GND
N.C.	11	12	DDCDATA
HSYNC	13	14	VSYNC
DDCCLK	15		

USB1: USB1/2 Ports

USBLAN1: 10/100/1000 RJ-45 and USB3/4 Ports

USBLAN2: 10/100/1000 RJ-45 and USB5/6 Ports (option)

AUDIO1: Audio Connector

SATA1, SATA2: Serial ATA Connectors

PE1: Mini PCI- E(x1) Connector (bottom side) (option)

J1: Compact Flash Connector (bottom side) (option)

PCI1: PCI Slot (supports 2 Master)

PCIE1: PCIE x1 Slot

IDE1: IDE Connector

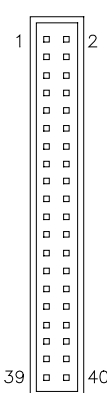

Signal Name	Pin #	Pin #	Signal Name
Reset IDE	1	2	Ground
Host data 7	3	4	Host data 8
Host data 6	5	6	Host data 9
Host data 5	7	8	Host data 10
Host data 4	9	10	Host data 11
Host data 3	11	12	Host data 12
Host data 2	13	14	Host data 13
Host data 1	15	16	Host data 14
Host data 0	17	18	Host data 15
Ground	19	20	Protect pin
DRQ0	21	22	Ground
Host IOW	23	24	Ground
Host IOR	25	26	Ground
IOCHRDY	27	28	Host ALE
DACK0	29	30	Ground
IRQ14	31	32	No connect
Address 1	33	34	No connect
Address 0	35	36	Address 2
Chip select 0	37	38	Chip select 1
Activity	39	40	Ground

CON10: LCD Backlight Connector

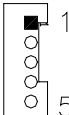

Pin #	Signal Name
1	+12V
2	Ground
3	Backlight Enable
4	Backlight ADJ
5	+5V

PWR1: HDD Power Connector (Output: Max. 2A)

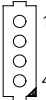

Pin #	Signal Name
1	+12V
2	Ground
3	Ground
4	5V

Note: +12V power is provided with 2A maximum load.

CON9: ATX_12V Connector

ATX12V1 is a DC-in internal connector supporting +12V .

Remarks: CON9 and ATX12V1 connectors cannot be connected at the same time.



Pin #	Signal Name
1	Ground
2	Ground
3	+12V
4	+12V

PANEL1: Power LED Connector

Pin #	Signal Name
2	Vcc
4	Ground

CON6: Digital I/O



Signal Name	Pin	Pin	Signal Name
GND	1	2	VCC
OUT3	3	4	OUT1
OUT2	5	6	OUT0
IN3	7	8	IN1
IN2	9	10	IN0

CON5: COM1, COM2 Serial Ports

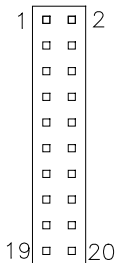

Pin #	Signal Name (RS-232)
1/11	DCD, Data carrier detect
3/13	RXD, Receive data
5/15	TXD, Transmit data
7/17	DTR, Data terminal ready
9/19	Ground
2/12	DSR, Data set ready
4/14	RTS, Request to send
6/16	CTS, Clear to send
8/18	RI, Ring indicator
10/20	Ground

*COM2 supports RS-232/422/485.

LVDS2, LVDS4: LVDS Connectors (1st channel, 2nd channel)

The LVDS connectors on board consist of the first channel and second channel and supports 18-bit/24-bit.

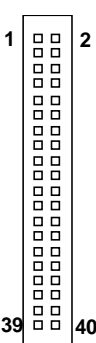

Signal Name	Pin #	Pin #	Signal Name
5V	2	1	3V
5V	4	3	3V
Ground	6	5	Ground
SD_DC2	8	7	SC_DC2
Ground	10	9	Ground
CLK1+	12	11	CLK2-
CLK1-	14	13	CLK2+
Ground	16	15	Ground
A0+	18	17	A4-
A0-	20	19	A4+
Ground	22	21	Ground
A1+	24	23	A5-
A1-	26	25	A5+
Ground	28	27	Ground
A2+	30	29	A6-
A2-	32	31	A6+
Ground	34	33	Ground
A3+	36	35	A7-
A3-	38	37	A7+
+12V	40	39	+12V

PANEL1: System Function Connector

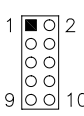

Signal Name	Pin	Pin	Signal Name
HD_LED+	1	2	PW_LED+
HD_LED-	3	4	PW_LED-
RT_BT1	5	6	PW_BT1
RT_BT2	7	8	PW_BT2
5VSB	9	10	RSEV

ATX power on switch: Pins 6-8

HDD LED: Pins 1-3

Reset switch: Pins 5-7

CON3: COM3, COM4 Serial Ports

Pin #	Signal Name (RS-232)
1/11	DCD, Data carrier detect
3/13	RXD, Receive data
5/15	TXD, Transmit data
7/17	DTR, Data terminal ready
9/19	Ground
2/12	DSR, Data set ready
4/14	RTS, Request to send
6/16	CTS, Clear to send
8/18	RI, Ring indicator
10/20	Ground

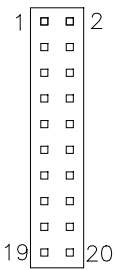

J4: USB3/4 Port Pin Header



Signal Name	Pin	Pin	Signal Name
Vcc	1	5	Ground
D-	2	6	D+
D+	3	7	D-
Ground	4	8	Vcc

J2,J3: Audio Front Header

Signal Name	Pin #	Pin #	Signal Name
OUT_L	1	2	Ground
OUT_R	1	2	Ground

CON11: Smart Battery Connector



Pin #	Signal Name
1	PCIRST-
2	EMTSMI-
3	Ground
4	SMBDATA
5	SMBCLK

LPT1: Parallel Port

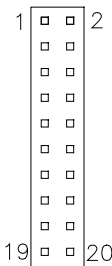

Signal Name	Pin #	Pin #	Signal Name
STB-	1	2	BUSY
PD0	3	4	PE
PD1	5	6	SLCT
PD2	7	8	AFD-
PD3	9	10	ERR-
PD4	11	12	INIT-
PD5	13	14	SLIN-
PD6	15	16	Ground
PD7	17	18	Ground
ACK-	19	20	Protect Pin

This page is intentionally left blank.

BIOS Setup

This chapter describes the different settings available in the Award BIOS that comes with the board. The topics covered in this chapter are as follows:

BIOS Introduction	24
BIOS Setup	24
Standard CMOS Setup.....	26
Advanced BIOS Features.....	29
Advanced Chipset Features.....	32
Integrated Peripherals	35
Power Management Setup	39
PNP/PCI Configurations.....	42
PC Health Status	43
Frequency/Voltage Control.....	44
Load Fail-Safe Defaults	45
Load Optimized Defaults.....	45
Set Supervisor/User Password	45
Save & Exit Setup.....	45
Exit Without Saving.....	45

BIOS Introduction

The Award BIOS (Basic Input/Output System) installed in your computer system's ROM supports Intel processors. The BIOS provides critical low-level support for a standard device such as disk drives, serial ports and parallel ports. It also adds virus and password protection as well as special support for detailed fine-tuning of the chipset controlling the entire system.

BIOS Setup

The Award BIOS provides a Setup utility program for specifying the system configurations and settings. The BIOS ROM of the system stores the Setup utility. When you turn on the computer, the Award BIOS is immediately activated. Pressing the key immediately allows you to enter the Setup utility. If you are a little bit late pressing the key, POST (Power On Self Test) will continue with its test routines, thus preventing you from invoking the Setup. If you still wish to enter Setup, restart the system by pressing the "Reset" button or simultaneously pressing the <Ctrl>, <Alt> and <Delete> keys. You can also restart by turning the system Off and back On again. The following message will appear on the screen:

```
Press <DEL> to Enter Setup
```

In general, you press the arrow keys to highlight items, <Enter> to select, the <PgUp> and <PgDn> keys to change entries, <F1> for help and <Esc> to quit.

When you enter the Setup utility, the Main Menu screen will appear on the screen. The Main Menu allows you to select from various setup functions and exit choices.

Phoenix - AwardBIOS CMOS Setup Utility

Standard CMOS Features	Frequency/Voltage Control
Advanced BIOS Features	Load Fail-Safe Defaults
Advanced Chipset Features	Load Optimized Defaults
Integrated Peripherals	Set Supervisor Password
Power Management Setup	Set User Password
PnP/PCI Configurations	Save & Exit Setup
PC Health Status	Exit Without Saving
ESC : Quit	↑ ↓ → ← : Select Item
F10 : Save & Exit Setup	
Time, Date, Hard Disk Type...	

The section below the setup items of the Main Menu displays the control keys for this menu. At the bottom of the Main Menu just below the control keys section, there is another section, which displays information on the currently highlighted item in the list.

Note: *If the system cannot boot after making and saving system changes with Setup, the Award BIOS supports an override to the CMOS settings that resets your system to its default.*

Warning: *It is strongly recommended that you avoid making any changes to the chipset defaults. These defaults have been carefully chosen by both Award and your system manufacturer to provide the absolute maximum performance and reliability. Changing the defaults could cause the system to become unstable and crash in some cases.*

Standard CMOS Setup

“Standard CMOS Setup” choice allows you to record some basic hardware configurations in your computer system and set the system clock and error handling. If the motherboard is already installed in a working system, you will not need to select this option. You will need to run the Standard CMOS option, however, if you change your system hardware configurations, the onboard battery fails, or the configuration stored in the CMOS memory was lost or damaged.

Phoenix - AwardBIOS CMOS Setup Utility
Standard CMOS Features

		Item Help
Date (mm:dd:yy)	Fri, Mar 23, 2007	Menu Level > Change the day, month, Year and century
Time (hh:mm:ss)	00 : 00 : 00	
IDE Channel 0 Master	None	
IDE Channel 0 Slave	None	
IDE Channel 1 Master	None	
IDE Channel 1 Slave	None	
Video	EGA/VGA	
Halt On	All, Errors	
Base Memory	640K	
Extended Memory	514048K	
Total Memory	515072K	

At the bottom of the menu are the control keys for use on this menu. If you need any help in each item field, you can press the <F1> key. It will display the relevant information to help you. The memory display at the lower right-hand side of the menu is read-only. It will adjust automatically according to the memory changed. The following describes each item of this menu.

Date

The date format is:

Day : Sun to Sat
Month : 1 to 12
Date : 1 to 31
Year : 1999 to 2099

To set the date, highlight the “Date” field and use the PageUp/ PageDown or +/- keys to set the current time.

Time

The time format is: **Hour : 00 to 23**
Minute : 00 to 59
Second : 00 to 59

To set the time, highlight the "Time" field and use the <PgUp>/ <PgDn> or +/- keys to set the current time.

IDE Channel Master/Slave

The onboard PCI IDE connector provides Primary and Secondary channels for connecting up to two IDE hard disks or other IDE devices.

Press <Enter> to configure the hard disk. The selections include Auto, Manual, and None. Select 'Manual' to define the drive information manually. You will be asked to enter the following items.

Capacity :	Capacity/size of the hard disk drive
CYLS :	Number of cylinders
HEAD :	Number of read/write heads
PRECOMP :	Write precompensation
LANDING ZONE :	Landing zone
SECTOR :	Number of sectors

The Access Mode selections are as follows:

CHS	(HD < 528MB)
LBA	(HD > 528MB and supports Logical Block Addressing)
Large	(for MS-DOS only)
Auto	

Remarks: The main board supports two serial ATA ports and are represented in this setting as IDE Channel 0.

Video

This field selects the type of video display card installed in your system. You can choose the following video display cards:

EGA/VGA	For EGA, VGA, SEGA, SVGA or PGA monitor adapters. (default)
CGA 40	Power up in 40 column mode.
CGA 80	Power up in 80 column mode.
MONO	For Hercules or MDA adapters.

Halt On

This field determines whether or not the system will halt if an error is detected during power up.

- | | |
|-------------------|---|
| No errors | The system boot will not be halted for any error that may be detected. |
| All errors | Whenever the BIOS detects a non-fatal error, the system will stop and you will be prompted. |
| All, But Keyboard | The system boot will not be halted for a keyboard error; it will stop for all other errors |

Advanced BIOS Features

This section allows you to configure and improve your system and allows you to set up some system features according to your preference.

Phoenix - AwardBIOS CMOS Setup Utility
Advanced BIOS Features

		ITEM HELP
CPU Feature	Press Enter	
Hard Disk Boot Priority	Press Enter	
Virus Warning	Disabled	Menu Level >
CPU L1 and L2 Cache	Enabled	
CPU L3 Cache	Enabled	
Hyper-Threading Technology	Enabled	
Quick Power On Self Test	Enabled	
First Boot Device	Hard Disk	
Second Boot Device	CDROM	
Third Boot Device	USB-FDD	
Boot Other Device	Enabled	
Boot Up NumLock Status	On	
Gate A20 Option	Fast	
Typematic Rate Setting	Disabled	
Typematic Rate (Chars/Sec)	6	
Typematic Delay (Msec)	250	
Security Option	Setup	
APIC Mode	Enabled	
MPS Version Control for OS	1.4	
OS Select For DRAM>64MB	Non-OS2	
Small Logo (EPA) Show	Disabled	

CPU Feature

Press Enter to configure the settings relevant to CPU Feature.

Hard Disk Boot Priority

With the field, there is the option to choose, aside from the hard disks connected, "Bootable add-in Cards" which refers to other external devices.

Virus Warning

If this option is enabled, an alarm message will be displayed when trying to write on the boot sector or on the partition table on the disk, which is typical of the virus.

CPU L1 / L2 / L3 Cache

Cache memory is additional memory that is much faster than conventional DRAM (system memory). CPUs from 486-type on up contain internal cache memory, and most, but not all, modern PCs have additional (external) cache memory. When the CPU requests data, the system transfers the requested data from the main DRAM into cache memory, for even faster access by the CPU. These items allow you to enable (speed up memory access) or disable the cache function. By default, these items are Enabled.

Hyper-Threading Technology

By default, this function is enabled.

Quick Power On Self Test

When enabled, this field speeds up the Power On Self Test (POST) after the system is turned on. If it is set to *Enabled*, BIOS will skip some items.

First/Second/Third Boot Device

These fields determine the drive that the system searches first for an operating system. The options available include *Floppy*, *LS120*, *Hard Disk*, *CDROM*, *ZIP100*, *USB-Floppy*, *USB-ZIP*, *USB-CDROM*, *LAN* and *Disable*.

Boot Other Device

These fields allow the system to search for an OS from other devices other than the ones selected in the First/Second/Third Boot Device.

Boot Up NumLock Status

This allows you to activate the NumLock function after you power up the system.

Gate A20 Option

This field allows you to select how Gate A20 is worked. Gate A20 is a device used to address memory above 1 MB.

Typematic Rate Setting

When disabled, continually holding down a key on your keyboard will generate only one instance. When enabled, you can set the two typematic controls listed next. By default, this field is set to *Disabled*.

Typematic Rate (Chars/Sec)

When the typematic rate is enabled, the system registers repeated keystrokes speeds. Settings are from 6 to 30 characters per second.

Typematic Delay (Msec)

When the typematic rate is enabled, this item allows you to set the time interval for displaying the first and second characters. By default, this item is set to *250msec*.

Security Option

This field allows you to limit access to the System and Setup. The default value is *Setup*. When you select *System*, the system prompts for the User Password every time you boot up. When you select *Setup*, the system always boots up and prompts for the Supervisor Password only when the Setup utility is called up.

APIC Mode

APIC stands for Advanced Programmable Interrupt Controller. The default setting is *Enabled*.

MPS Version Control for OS

This option specifies the MPS (Multiprocessor Specification) version for your operating system. MPS version 1.4 added extended configuration tables to improve support for multiple PCI bus configurations and improve future expandability. The default setting is *1.4*.

OS Select for DRAM > 64MB

This option allows the system to access greater than 64MB of DRAM memory when used with OS/2 that depends on certain BIOS calls to access memory. The default setting is *Non-OS/2*.

Small Logo (EPA) Show

The EPA logo appears at the right side of the monitor screen when the system is boot up. The default setting is *Disabled*.

Advanced Chipset Features

This Setup menu controls the configuration of the chipset.

Phoenix - AwardBIOS CMOS Setup Utility
Advanced Chipset Features

		ITEM HELP
DRAM Timing Selectable	By SPD	Menu Level >
CAS Latency Time	Auto	
DRAM RAS# to CAS# Delay	Auto	
DRAM RAS# Precharge	Auto	
Precharge delay (tRAS)	Auto	
System Memory Frequency	Auto	
SLP_S4# Assertion Width	4 to 5 Sec	
System BIOS Cacheable	Enabled	
Video BIOS Cacheable	Disabled	
Memory Hole at 15M-16M	Disabled	
PCI Express Root Port Func	Press Enter	
** On-Chip VGA Setting **		
On-Chip Frame Buffer Size	8MB	
DVMT Mode	DVMT	
DVMT/FIXED memory Size	128MB	
SDVO Device Setting	NONE	
SDVO LVDS Protocol	1 CH SPGW 18bit	
SDVO Panel Number	640 x 480	
Boot Display	CRT	
Panel Scaling	Auto	
Panel Number	1024x768 18 bit SC	

DRAM Timing Selectable

This option refers to the method by which the DRAM timing is selected. The default is **By SPD**.

CAS Latency Time

You can configure CAS latency time in HCLKs as 2 or 2.5 or 3. The system board designer should set the values in this field, depending on the DRAM installed. Do not change the values in this field unless you change specifications of the installed DRAM or the installed CPU.

DRAM RAS# to CAS# Delay

This option allows you to insert a delay between the RAS (Row Address Strobe) and CAS (Column Address Strobe) signals. This delay occurs when the SDRAM is written to, read from or refreshed. Reducing the delay improves the performance of the SDRAM.

DRAM RAS# Precharge

This option sets the number of cycles required for the RAS to accumulate its charge before the SDRAM refreshes. The default setting for the Active to Precharge Delay is Auto.

Precharge Delay (tRAS)

The default setting for the Precharge Delay is *Auto*.

System Memory Frequency

The default setting is *Auto*.

SLP_S4# Assertion Width

The default setting is *4 to 5 Sec*.

System BIOS Cacheable

The setting of *Enabled* allows caching of the system BIOS ROM at F000h-FFFFh, resulting in better system performance. However, if any program writes to this memory area, a system error may result.

Video BIOS Cacheable

The Setting *Enabled* allows caching of the video BIOS ROM at C0000h-F7FFFh, resulting in better video performance. However, if any program writes to this memory area, a system error may result.

Memory Hole At 15M-16M

In order to improve performance, certain space in memory can be reserved for ISA cards. This memory must be mapped into the memory space below 16 MB. The choices are *Enabled* and *Disabled*.

On-Chip VGA Setting

The fields under the On-Chip VGA Setting and their default settings are:

- PEG/On Chip VGA Control: Auto
- On-Chip Frame Buffer Size: 8MB
- DVMT Mode: DVMT
- DVMT/Fixed Memory Size: 128MB
- SDVO Device Setting: NONE
- SDVO LVDS Protocol: 1Ch SPGW 18bit
- SDVO Panel Number: 640 x 480
- Boot Display: CRT
- Panel Scaling: Auto
- Panel Number: 1024x768 18 bit SC

Panel Scaling

The default setting is *Auto*. The options available include *On* and *Off*.

Panel Number

These fields allow you to select the LCD Panel type. The default values for these ports are:

640x480	18bit SC
800x480	18bit SC
800x600	18bit SC
1024x768	18bit SC
1280x1024	18bit DC
1280x768	18bit SC
1280x800	18bit SC
1400x1050	18bit DC
1400x900	18bit DC
1600x1200	18bit DC
1920x1200	18bit DC
1366x768	18bit SC
1920x1080	18bit DC

Integrated Peripherals

This section sets configurations for your hard disk and other integrated peripherals. The first screen shows three main items for user to select. Once an item selected, a submenu appears. Details follow.

Phoenix - AwardBIOS CMOS Setup Utility
Integrated Peripherals

OnChip IDE Device	Press Enter	ITEM HELP
Onboard Device	Press Enter	Menu Level >
SuperIO Device	Press Enter	
2 nd SuperIO Device	Press Enter	

Phoenix - AwardBIOS CMOS Setup Utility
OnChip IDE Device

IDE HDD Block Mode	Enabled	ITEM HELP
IDE DMA transfer access	Enabled	
On-chip Primary PCI IDE	Enabled	
IDE Primary Master PIO	Auto	Menu Level >
IDE Primary Slave PIO	Auto	
IDE Primary Master UDMA	Auto	
IDE Primary Slave UDMA	Auto	
On-Chip Secondary PCI IDE	Enabled	
IDE Secondary Master PIO	Auto	
IDE Secondary Slave PIO	Auto	
IDE Secondary Master UDMA	Auto	
IDE Secondary Slave UDMA	Auto	
*** On-Chip Serial ATA Setting ***		
SATA Mode	IDE	
On-Chip Serial ATA	Auto	
SATA Port Speed Settings	Disabled	
PATA IDE Mode	Primary	
SATA port	P1, P3 is Secondary	

Phoenix - AwardBIOS CMOS Setup Utility
Onboard Device

USB Controller	Enabled	ITEM HELP
USB 2.0 Controller	Enabled	Menu Level >
USB Keyboard Support	Enabled	
Azalia AC97 Audio Select	Auto	

Phoenix - AwardBIOS CMOS Setup Utility
SuperIO Device

POWER ON Function	BUTTON ONLY	ITEM HELP
KB Power ON Password	Enter	
Hot Key power ON	Ctrl-F1	
Onboard Serial Port 1	3F8/IRQ4	Menu Level >
Onboard Serial Port 2	2F8/IRQ3	
Onboard Parallel Port	378/IRQ7	
Parallel Port Mode	SPP	
EPP Mode Select	EPP1.7	
ECP Mode Use DMA	3	
PWRON After PWR-Fail	Off	

Onboard Serial Port 3	2B0h	ITEM HELP
Serial Port 3 Use IRQ	IRQ11	Menu Level >
Onboard Serial Port 4	2B8h	
Serial Port 4 Use IRQ	IRQ10	

IDE HDD Block Mode

This field allows your hard disk controller to use the fast block mode to transfer data to and from your hard disk drive.

IDE DMA Transfer Access

This field, by default, is enabled

On-chip Primary PCI IDE Enabled

This field, by default, is enabled

OnChip Primary/Secondary PCI IDE

The integrated peripheral controller contains an IDE interface with support for two IDE channels. Select *Enabled* to activate each channel separately.

IDE Primary/Secondary Master/Slave PIO

These fields allow your system hard disk controller to work faster. Rather than have the BIOS issue a series of commands that transfer to or from the disk drive, PIO (Programmed Input/Output) allows the BIOS to communicate with the controller and CPU directly.

The system supports five modes, numbered from 0 (default) to 4, which primarily differ in timing. When Auto is selected, the BIOS will select the best available mode.

IDE Primary/Secondary Master/Slave UDMA

These fields allow your system to improve disk I/O throughput to 33Mb/sec with the Ultra DMA/33 feature. The options are *Auto* and *Disabled*.

On-Chip Serial ATA Setting

The fields under the SATA setting includes SATA Mode (IDE), On-Chip Serial ATA (Auto), PATA IDE Mode (Secondary) and SATA Port (P0, P1 is Primary).

USB Controller

The options for this field are *Enabled* and *Disabled*. By default, this field is set to *Enabled*.

USB 2.0 Controller

The options for this field are *Enabled* and *Disabled*. By default, this field is set to *Enabled*. In order to use USB 2.0, necessary OS drivers must be installed first. *Please update your system to Windows 2000 SP4 or Windows XP SP2.*

USB Keyboard Support

By default, the USB keyboard function is set to *Enabled*.

Azalia AC97 Audio Select

This field, by default, is set to *Auto*. The selections are *Azalia, AC97 Audio and Modem, AC97 Audio only, AC97 Modem only, and All Disabled*.

Power ON Function

This field is related to how the system is powered on – such as with the use of conventional power button, keyboard or hot keys. The default is *BUTTON ONLY*.

KB Power ON Password

This field allows users to set the password when keyboard power on is the mode of the Power ON function.

Hot Key Power ON

This field sets certain keys, also known as hot keys, on the keyboard that can be used as a ‘switch’ to power on the system.

Onboard Serial Port

These fields allow you to select the onboard serial ports and their addresses. The default values for these ports are:

Serial Port 1	3F8/IRQ4
Serial Port 2	2F8/IRQ3

Onboard Parallel

These fields allow you to select the parallel ports and their addresses. The default values for these ports are:

Parallel Port	378H/IRQ7
---------------	-----------

Parallel Port Mode

This field allows you to determine parallel port mode function.

SPP	Standard Printer Port
EPP	Enhanced Parallel Port
ECP	Extended Capabilities Port
ECP+EPP	Combination of ECP and EPP capabilities
Normal	Normal function

PWRON After PWR-Fail

This field sets the system power status whether *on* or *off* when power returns to the system from a power failure situation.

Power Management Setup

Phoenix - AwardBIOS CMOS Setup Utility
Power Management Setup

		ITEM HELP
Power-Supply Type	ATX	
ACPI Function	Enabled	
ACPI Suspend	S1(POS)	
RUN VGABIOS if S3 Resume	Auto	Menu Level >
Power Management	User Define	
Video Off Method	DPMS	
Video Off In Suspend	Yes	
Suspend Type	Stop Grant	
Modem Use IRQ	3	
Suspend Mode	Disabled	
HDD Power Down	Disabled	
Soft-Off by PWR-BTTN	Instant-Off	
CPU THRM-Throttling	75%	
Wake-Up by PCI Card	Disabled	
Power On by Ring	Disabled	
USB KB Wakeup from S3	Disabled	
Resume by Alarm	Disabled	
Date (of Month) Alarm	0	
Time (hh:mm:ss) Alarm	0 : 0 : 0	
** Reload Global Timer Events **		
Primary IDE 0	Disabled	
Primary IDE 1	Disabled	
Secondary IDE 0	Disabled	
Secondary IDE 1	Disabled	
FDD, COM, LPT Port	Disabled	
PCI PIRQ[A-D] #	Disabled	

ACPI Function

ACPI stands for Advance Configuration and Power Interface.

ACPI Suspend

The default setting of the ACPI Suspend mode is *SI(POS)*.

RUN VGABIOS if S3 Resume

The default setting of this field is *Auto*.

Power Management

This field allows you to select the type of power saving management modes. There are four selections for Power Management.

Min. Power Saving	Minimum power management
Max. Power Saving	Maximum power management.
User Define	Each of the ranges is from 1 min. to 1hr. Except for HDD Power Down which ranges from 1 min. to 15 min.

Video Off Method

This field defines the Video Off features. There are three options.

V/H SYNC + Blank	Default setting, blank the screen and turn off vertical and horizontal scanning.
DPMS	Allows BIOS to control the video display.
Blank Screen	Writes blanks to the video buffer.

Video Off In Suspend

When enabled, the video is off in suspend mode.

Suspend Type

The default setting for the Suspend Type field is *Stop Grant*.

Modem Use IRQ

This field sets the IRQ used by the Modem. By default, the setting is 3.

Suspend Mode

When enabled, and after the set time of system inactivity, all devices except the CPU will be shut off.

HDD Power Down

When enabled, and after the set time of system inactivity, the hard disk drive will be powered down while all other devices remain active.

Soft-Off by PWRBTN

This field defines the power-off mode when using an ATX power supply. The *Instant Off* mode allows powering off immediately upon pressing the power button. In the *Delay 4 Sec* mode, the system powers off when the power button is pressed for more than four seconds or enters the suspend mode when pressed for less than 4 seconds.

Wake up by PCI Card

By default, this field is disabled.

Power On by Ring

This field enables or disables the power on of the system through the modem connected to the serial port or LAN.

USB KB Wakeup from S3

By default, this field is disabled.

Resume by Alarm

This field enables or disables the resumption of the system operation. When enabled, the user is allowed to set the *Date* and *Time*.

Reload Global Timer Events

The HDD, FDD, COM, LPT Ports, and PCI PIRQ are I/O events that can prevent the system from entering a power saving mode or can awaken the system from such a mode. When an I/O device wants to gain the attention of the operating system, it signals this by causing an IRQ to occur. When the operating system is ready to respond to the request, it interrupts itself and performs the service.

PNP/PCI Configurations

This option configures the PCI bus system. All PCI bus systems on the system use INT#, thus all installed PCI cards must be set to this value.

Phoenix - AwardBIOS CMOS Setup Utility
PnP/PCI Configurations

Init Display First	PCI Slot	ITEM HELP
Reset Configuration Data	Disabled	
Resources Controlled By	Auto (ESCD)	Menu Level
IRQ Resources	Press Enter	Select Yes if you are using a Plug and Play capable operating system Select No if you need the BIOS to configure non-boot devices
PCI/VGA Palette Snoop	Disabled	
PCI Express relative items		
Maximum Payload Size	128	

Init Display First

The default setting is *PCI Card*.

Reset Configuration Data

This field allows you to determine whether to reset the configuration data or not. The default value is *Disabled*.

Resources Controlled by

This PnP BIOS can configure all of the boot and compatible devices with the use of a PnP operating system such as Windows 95.

PCI/VGA Palette Snoop

Some non-standard VGA display cards may not show colors properly. This field allows you to set whether or not MPEG ISA/VESA VGA cards can work with PCI/VGA. When this field is enabled, a PCI/VGA can work with an MPEG ISA/VESA VGA card. When this field is disabled, a PCI/VGA cannot work with an MPEG ISA/VESA card.

Maximum Payload Size

The default setting of the PCI Express Maximum Payload Size is 4096.

PC Health Status

This section shows the parameters in determining the PC Health Status. These parameters include temperatures, fan speeds and voltages.

Phoenix - AwardBIOS CMOS Setup Utility
PC Health Status

		ITEM HELP
Shutdown Temperature	Disabled	
CPU Warning Temperature	Disabled	
Current System Temp	45°C/113°F	
Current CPU Temp	45°C/113°F	
FAN1 Speed	5400 RPM	
FAN2 Speed	5400 RPM	
Vcore(V)	1.02 V	
+12 V	1.32 V	
Vmem	1.8V	
+5V	5.25 V	
3.3V	3.37V	
VBAT (V)	3.21 V	
3.3VSB(V)	3.26 V	
LCD Back Light Control	63	
		Menu Level >

CPU Warning Temperature

This field allows the user to set the temperature so that when the temperature is reached, the system sounds a warning. This function can help prevent damage to the system that is caused by overheating.

Temperatures/Voltages

These fields are the parameters of the hardware monitoring function feature of the motherboard. The values are read-only values as monitored by the system and show the PC health status.

Smart Fan Temperature

There are two smart fan functions available. When enabled, the user is allowed to set a threshold temperature which determines when the CPU/system fan would stop rotating.

Frequency/Voltage Control

This section shows the user how to configure the processor frequency.

Phoenix - AwardBIOS CMOS Setup Utility
Frequency/Voltage Control

Auto Detect PCI Clk	Disabled	ITEM HELP
Spread Spectrum	Disabled	
CPU Host/SRC PCI Clock	Default	

Auto Detect PCI Clk

This field enables or disables the auto detection of the PCI clock.

Spread Spectrum Modulated

This field sets the value of the spread spectrum. The default setting is *Disabled*. This field is for CE testing use only.

CPU Host / SRC PCI Clock

This field is set to *Default*.

Load Fail-Safe Defaults

This option allows you to load the troubleshooting default values permanently stored in the BIOS ROM. These default settings are non-optimal and disable all high-performance features.

Load Optimized Defaults

This option allows you to load the default values to your system configuration. These default settings are optimal and enable all high performance features.

Set Supervisor Password

These two options set the system password. Supervisor Password sets a password that will be used to protect the system and Setup utility. User Password sets a password that will be used exclusively on the system. To specify a password, highlight the type you want and press <Enter>. The Enter Password: message prompts on the screen. Type the password, up to eight characters in length, and press <Enter>. The system confirms your password by asking you to type it again. After setting a password, the screen automatically returns to the main screen.

To disable a password, just press the <Enter> key when you are prompted to enter the password. A message will confirm the password to be disabled. Once the password is disabled, the system will boot and you can enter Setup freely.

Save & Exit Setup

This option allows you to determine whether or not to accept the modifications. If you type “Y”, you will quit the setup utility and save all changes into the CMOS memory. If you type “N”, you will return to Setup utility.

Exit Without Saving

Select this option to exit the Setup utility without saving the changes you have made in this session. Typing “Y” will quit the Setup utility without saving the modifications. Typing “N” will return you to Setup utility.

This page is intentionally left blank.

Drivers Installation

This section describes the installation procedures for software and drivers under the Windows 2000 and Windows XP. The software and drivers are included with the motherboard. If you find the items missing, please contact the vendor where you made the purchase. The contents of this section include the following:

Intel Chipset Software Installation Utility	48
VGA Drivers Installation.....	49
Realtek High Definition Audio Driver Installation.....	50
LAN Drivers Installation	51

IMPORTANT NOTE:

After installing your Windows operating system (Windows 2000/ XP), you must install first the Intel Chipset Software Installation Utility before proceeding with the drivers installation.

When you are putting the CD Support you will get a menu:



Intel Chipset Software Installation Utility

The Intel Chipset Drivers should be installed first before the software drivers to enable Plug & Play INF support for Intel chipset components. Follow the instructions below to complete the installation under Windows 2000/XP.

1. Insert the CD that comes with the board. Click on Chipsets from the top menu.



2. When the Welcome screen to the Intel(R) Chipset Software Installation Utility appears, click **Next** to continue.

3. Click **Yes** to accept the software license agreement and proceed with the installation process.

4. In the Readme File Information window, click **Next** to continue to proceed with the installation process.

8. The utility setup is now complete. Click **Finish** to restart the computer.

VGA Drivers Installation

To install the VGA drivers, follow the steps below to proceed with the installation.

1. Insert the CD that comes with the board. Click **VIDEO**

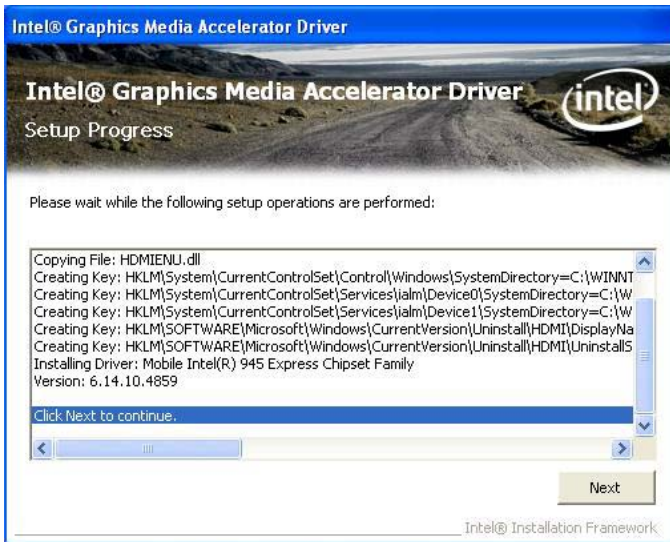

2. When the Welcome screen to the Setup Program appears, click **Next** to continue.
3. Click **Yes** to agree with the license agreement and continue the installation process.
4. On Readme File Information screen, click **Next** to continue.
5. In the Setup Progress screen, click **Next** to continue the installation.
6. Setup is now complete. Click **Finish** to restart the computer.

Realtek Ac97 Audio Driver Installation

Follow the steps below to install the Realtek AC97 Codec Audio Drivers.

1. Insert the CD that comes with the motherboard. Click Audio

After menu popup loading setup this screen will show-up.

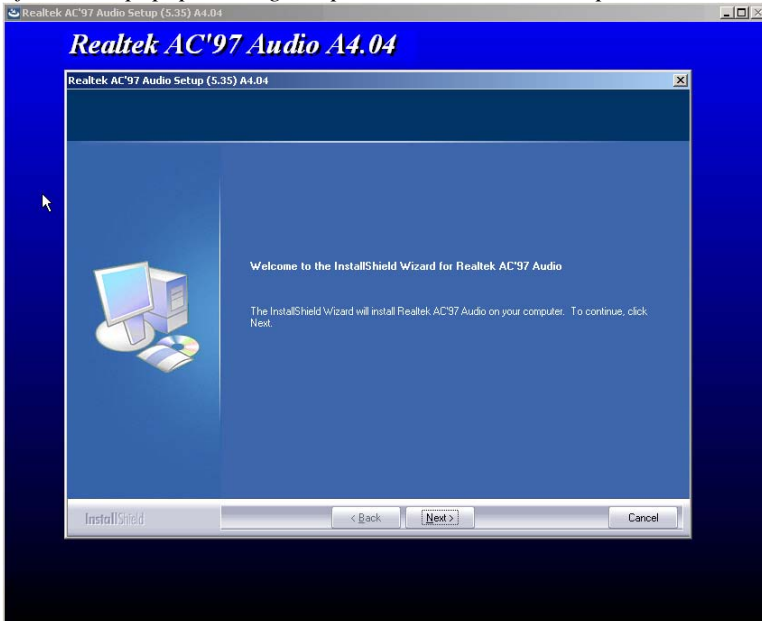

2. When the Welcome to the InstallShield Wizard to Realtek AC97 Audio Driver screen appears, click **Next** to continue.
3. Setup has finished installing Realtek AC97 Audio Driver on your computer. Click **Finish** to restart the computer.

LAN Drivers Installation

Follow the steps below to install the **Realtek RTL811C LAN Drivers**.

1. Insert the CD that comes with the board. Click NETWORK..

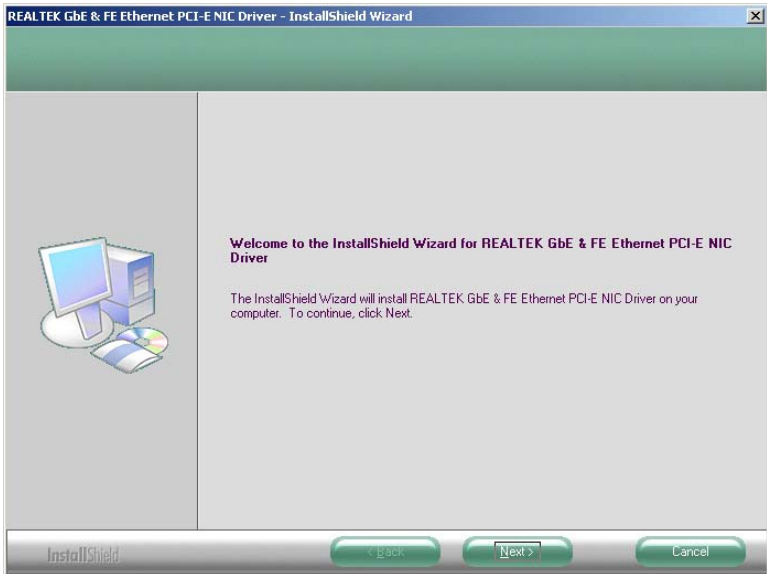

2. When the Welcome InstallShield Wizard present, click **NEXT**.

3. When the InstallShield Wizard has been completed, click **Finish**.

Appendix

A. I/O Port Address Map

Each peripheral device in the system is assigned a set of I/O port addresses which also becomes the identity of the device. The following table lists the I/O port addresses used.

Address	Device Description
000h - 01Fh	DMA Controller #1
020h - 03Fh	Interrupt Controller #1
040h - 05Fh	Timer
060h - 06Fh	Keyboard Controller
070h - 07Fh	Real Time Clock, NMI
080h - 09Fh	DMA Page Register
0A0h - 0BFh	Interrupt Controller #2
0C0h - 0DFh	DMA Controller #2
0F0h	Clear Math Coprocessor Busy Signal
0F1h	Reset Math Coprocessor
1F0h - 1F7h	IDE Interface
278 - 27F	Parallel Port #2(LPT2)
2F8h - 2FFh	Serial Port #2(COM2)
2B0 - 2DF	Graphics adapter Controller
378h - 3FFh	Parallel Port #1(LPT1)
360 - 36F	Network Ports
3B0 - 3BF	Monochrome & Printer adapter
3C0 - 3CF	EGA adapter
3D0 - 3DF	CGA adapter
3F0h - 3F7h	Floppy Disk Controller
3F8h - 3FFh	Serial Port #1(COM1)

B. Interrupt Request Lines (IRQ)

Peripheral devices use interrupt request lines to notify CPU for the service required. The following table shows the IRQ used by the devices on board.

Level	Function
IRQ0	System Timer Output
IRQ1	Keyboard
IRQ2	Interrupt Cascade
IRQ3	Serial Port #2
IRQ4	Serial Port #1
IRQ5	Reserved
IRQ6	Floppy Disk Controller
IRQ7	Parallel Port #1
IRQ8	Real Time Clock
IRQ9	Reserved
IRQ10	Reserved
IRQ11	Reserved
IRQ12	PS/2 Mouse
IRQ13	80287
IRQ14	Primary IDE
IRQ15	Secondary IDE

C. Watchdog Timer Configuration

The WDT is used to generate a variety of output signals after a user programmable count. The WDT is suitable for use in the prevention of system lock-up, such as when software becomes trapped in a deadlock. Under these sorts of circumstances, the timer will count to zero and the selected outputs will be driven. Under normal circumstance, the user will restart the WDT at regular intervals before the timer counts to zero.

SAMPLE CODE:

```

//=====
//
// THIS CODE AND INFORMATION IS PROVIDED "AS IS" WITHOUT WARRANTY OF ANY
// KIND, EITHER EXPRESSED OR IMPLIED, INCLUDING BUT NOT LIMITED TO THE
// IMPLIED WARRANTIES OF MERCHANTABILITY AND/OR FITNESS FOR A PARTICULAR
// PURPOSE.
//
//=====
#include <stdio.h>
#include <stdlib.h>
#include "W627EHF.H"
//=====
int main (int argc, char *argv[])
void copyright(void);
void EnableWDT(int);
void DisableWDT(void);
//=====
int main (int argc, char *argv[])
{
    unsigned char bBuf;
    unsigned char bTime;
    char **endptr;

    copyright();

    if (argc != 2)
    {
        printf(" Parameter incorrect!!\n");
        return 1;
    }

    if (Init_W627EHF() == 0)
    {
        printf(" Winbond 83627HF is not detected, program abort.\n");
        return 1;
    }
    bTime = strtol (argv[1], endptr, 10);
    printf("System will reset after %d seconds\n", bTime);

    EnableWDT(bTime);

    return 0;
}
//=====

```

```

void copyright(void)
{
    printf("\n===== Winbond 83627EHF Watch Timer Tester (AUTO DETECT) =====\n")
        "      Usage : W627E_WD reset_time\n"
        "      Ex : W627E_WD 3 => reset system after 3 second\n"
        "           W627E_WD 0 => disable watch dog timer\n");
}
//=====
void EnableWDT(int interval)
{
    unsigned char bBuf;

    bBuf = Get_W627EHF_Reg( 0x2D);
    bBuf &= (!0x01);
    Set_W627EHF_Reg( 0x2D, bBuf);           //Enable WDTO

    Set_W627EHF_LD( 0x08);                 //switch to logic device 8
    Set_W627EHF_Reg( 0x30, 0x01);         //enable timer

    bBuf = Get_W627EHF_Reg( 0xF5);
    bBuf &= (!0x08);
    Set_W627EHF_Reg( 0xF5, bBuf);         //count mode is second

    Set_W627EHF_Reg( 0xF6, interval);     //set timer
}
//=====
void DisableWDT(void)
{
    Set_W627EHF_LD(0x08);                 //switch to logic device 8
    Set_W627EHF_Reg(0xF6, 0x00);         //clear watchdog timer
    Set_W627EHF_Reg(0x30, 0x00);         //watchdog disabled
}
//=====

```

```

//=====
//
// THIS CODE AND INFORMATION IS PROVIDED "AS IS" WITHOUT WARRANTY OF ANY
// KIND, EITHER EXPRESSED OR IMPLIED, INCLUDING BUT NOT LIMITED TO THE
// IMPLIED WARRANTIES OF MERCHANTABILITY AND/OR FITNESS FOR A PARTICULAR
// PURPOSE.
//
//=====
#include "W627EHF.H"
#include <dos.h>
//=====
unsigned int W627EHF_BASE;
void Unlock_W627EHF (void);
void Lock_W627EHF (void);
//=====
unsigned int Init_W627EHF(void)
{
    unsigned int result;
    unsigned char ucDid;

    W627EHF_BASE = 0x2E;
    result = W627EHF_BASE;

    ucDid = Get_W627EHF_Reg(0x20);
    if (ucDid == 0x88)
    {   goto Init_Finish;   }

    W627EHF_BASE = 0x4E;
    result = W627EHF_BASE;
    ucDid = Get_W627EHF_Reg(0x20);
    if (ucDid == 0x88)
    {   goto Init_Finish;   }

    W627EHF_BASE = 0x00;
    result = W627EHF_BASE;

Init_Finish:
    return (result);
}
//=====
void Unlock_W627EHF (void)
{
    outportb(W627EHF_INDEX_PORT, W627EHF_UNLOCK);
    outportb(W627EHF_INDEX_PORT, W627EHF_UNLOCK);
}
//=====
void Lock_W627EHF (void)
{
    outportb(W627EHF_INDEX_PORT, W627EHF_LOCK);
}
//=====
void Set_W627EHF_LD( unsigned char LD)
{
    Unlock_W627EHF();
    outportb(W627EHF_INDEX_PORT, W627EHF_REG_LD);
    outportb(W627EHF_DATA_PORT, LD);
    Lock_W627EHF();
}

```

```

=====
void Set_W627EHF_Reg( unsigned char REG, unsigned char DATA)
{
    Unlock_W627EHF();
    outportb(W627EHF_INDEX_PORT, REG);
    outportb(W627EHF_DATA_PORT, DATA);
    Lock_W627EHF();
}
=====
unsigned char Get_W627EHF_Reg(unsigned char REG)
{
    unsigned char Result;
    Unlock_W627EHF();
    outportb(W627EHF_INDEX_PORT, REG);
    Result = inportb(W627EHF_DATA_PORT);
    Lock_W627EHF();
    return Result;
}
=====

=====
//
// THIS CODE AND INFORMATION IS PROVIDED "AS IS" WITHOUT WARRANTY OF ANY
// KIND, EITHER EXPRESSED OR IMPLIED, INCLUDING BUT NOT LIMITED TO THE
// IMPLIED WARRANTIES OF MERCHANTABILITY AND/OR FITNESS FOR A PARTICULAR
// PURPOSE.
//
=====
#ifndef __W627EHF_H
#define __W627EHF_H                1
=====
#define W627EHF_INDEX_PORT        (W627EHF_BASE)
#define W627EHF_DATA_PORT        (W627EHF_BASE+1)
=====
#define W627EHF_REG_LD            0x07
//
#define W627EHF_UNLOCK            0x87
#define W627EHF_LOCK              0xAA
=====
unsigned int Init_W627EHF(void);
void Set_W627EHF_LD( unsigned char);
void Set_W627EHF_Reg( unsigned char, unsigned char);
unsigned char Get_W627EHF_Reg( unsigned char);
//
=====
#endif // __W627EHF_H

```